



M+S HYDRAULIC

HEAVY DUTY MOTORS



HEAVY DUTY HYDRAULIC MOTORS

CONTENTS

	Page
● Hydraulic Motors Series MSWM	4
● Hydraulic Motors Series MTM	8
● Hydraulic Motors Series TMF	20
● Hydraulic Motors Series MVM	25
● Hydraulic Motors Series VMF	30
● Motor Special Features.....	34
● Motors with Speed Sensor.....	35
● Application Calculation	37

DISC VALVE HYDRAULIC MOTORS

GENERAL INFORMATION:

Orbit motors convert hydraulic energy (pressure, oil flow) into mechanical energy (torque, speed). Hydraulic orbit motors operate on the principle of an internal gear (rotor) rotating within a fixed external gear (stator). The internal gear transmits the torque generated by the application of pressure from hydraulic oil fed into motor which is then delivered via the motor's output shaft. Orbit motors have high starting torque and constant output torque at wide speed range. The output shaft runs on tapered roller bearings and can absorb high axial and radial forces.

DISTRIBUTOR VALVE

MSEM, MTM, TMF, MVM, VMF series motors have disk valve: the distributor valve has been separated from output shaft and is driven by short cardan shaft. A balance plate counterbalances the hydraulic forces around the distributor valve. It gives the motors high efficiency- even at high pressures, and good starting characteristics.

GEAR WHEEL SET

There are two forms of gear wheel set: Gerotor set have plain teeth and Roll-gerotor set with teeth fitted with rollers. MSEM, MTM, TMF, MVM, VMF series motors have roll-gerotor set. The rollers reduce local stress and the tangential reaction forces on the rotor reducing friction to a minimum. This gives long operating life and better efficiency even at continuous high pressures.

FEATURES:

Standard Motor

The standard motor mounting flange is located as close to the output shaft as possible. This type of mounting supports the motor close to the shaft load. This mounting flange is also compatible with many standard gear boxes.

Wheel Motor

The wheel motor mounting flange is located near the center of the motor which permits part or all of the motor to be located inside the wheel or roller hub. In traction drive applications, loads can be positioned over the motor bearings for best bearing life. This wheel motor mounting flange provides design flexibility in many applications.

Short Motor

This motor is assembled without the output shaft, bearings and bearing housing and has the same drive components as the standard motors. The short motor is especially suited for applications such as gear boxes, winch, reel and roll drives. Short motor applications must be designed with a bearing supported internal spline to mate with the short motor drive. Product designs using these hydraulic motors provide considerable cost savings.

Low Leakage

LL Series hydraulic motors are designed to operate at the whole standard range of working conditions (pressure drop and frequency of rotation), but with considerable decreased volumetric losses in the drain ports. This motors are suitable for hydraulic systems with series-connected motors with demands for low leakage.

Low Speed Valve

LSV feature optimizes the motor for low-speed performance. Motors with this valving provide very low speed while maintaining high torque. They are designed to run continuously at low speed (up to 200 RPM) at normal pressure drop and reduced flow. Optimal run is guaranteed at frequency of rotation from 20 to 50 RPM . Motors with this valving have an increased starting pressure and are not recommended for using at pressure drop less than 40 bar.

Motors with Speed Sensor

Motors are available with integrated inductive speed sensor. The output signal is a standardized voltage signal that can be used to control the speed of a motor. The torque and the radial load of the motor are not affected by the installation of speed sensor.

HYDRAULIC MOTORS MSWM



APPLICATION

- » Sawmill machines
- » Woodworking machines
- » Metal working machines
- » Agriculture machines
- » Road building machines
- » Mining machinery
- » Food industries
- » Special vehicles etc.

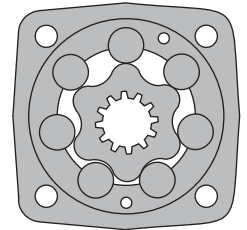
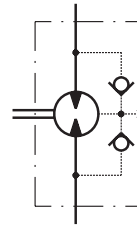

CONTENTS

Specification data	5
Dimensions and mounting	6
Permissible shaft loads	6
Shaft extensions	7
Order code	7

OPTIONS

- » Model- Disc valve, roll-gerotor
- » Wheel mount
- » Side and rear ports
- » Shafts- straight, splined and tapered
- » Metric and BSPP ports
- » Other special features

GENERAL

Max. Displacement, cm ³ /rev [in ³ /rev]	397 [24.2]
Max. Speed, [RPM]	560
Max. Torque, daNm [lb-in]	cont.: 90 [7965] int: 110 [9735]
Max. Output, kW [HP]	24 [32.2]
Max. Pressure Drop, bar [PSI]	cont.: 200 [2900] int: 225 [3270]
Max. Oil Flow, lpm [GPM]	90 [24]
Min. Speed, [RPM]	5
Pressure fluid	Mineral based- HLP(DIN 51524) or HM(ISO 6743/4)
Temperature range, °C [°F]	-40÷140 [-40÷284]
Optimal Viscosity range, mm ² /s [SUS]	20÷75 [98÷347]
Filtration	ISO code 20/16 (Min. recommended fluid filtration of 25 micron)

Oil flow in drain line

Pressure drop bar [PSI]	Viscosity mm ² /s [SUS]	Oil flow in drain line lpm [GPM]
140 [2030]	20 [98]	1,5 [.396]
	35 [164]	1 [.264]
210 [3045]	20 [98]	3 [.793]
	35 [164]	2 [.528]

Pressure Losses

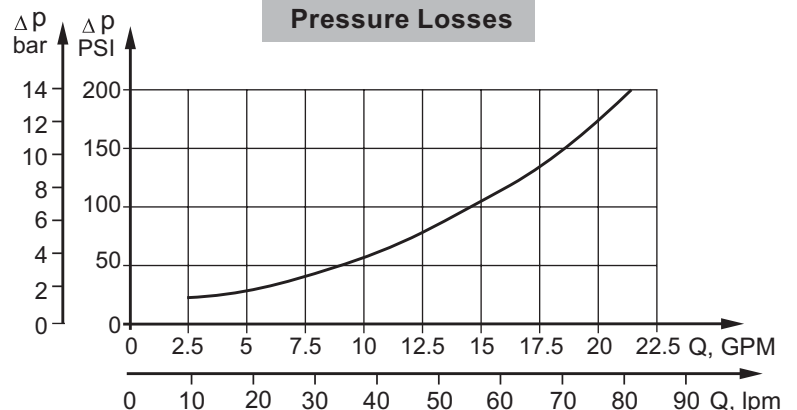

SPECIFICATION DATA

Type	MSWM 160	MSWM 200	MSWM 250	MSWM 315	MSWM 400	
Displacement, cm³/rev. [in³/rev.]	159,7 [9.74]	200 [12.2]	250 [15.3]	19.2 [314,9]	397 [24.2]	
Max. Speed, [RPM]	cont.	470	375	300	240	185
	Int.*	560	450	360	285	225
Max. Torque daNm [in- lb]	cont.	46 [4070]	56,6 [5010]	70,8 [6270]	90,0 [7965]	90,0 [7965]
	Int.*	51,5 [4560]	64,5 [5710]	80,6 [7135]	96,0 [8500]	97,0 [8585]
	peak**	51,5 [4560]	65 [5755]	80,6 [7135]	108 [9560]	110 [9735]
Max. Output kW [HP]	cont.	18,6 [24.9]	18,1 [24.3]	18,0 [24.1]	17,0 [22.8]	11,0 [14.7]
	int.*	24,0 [32.2]	24,0 [32.2]	23,8 [31.9]	20,2 [27.1]	12 [16.1]
Max. Pressure Drop bar [PSI]	cont.	200 [2900]	200 [2900]	200 [2900]	200 [2900]	160 [2320]
	Int.*	225 [3270]	225 [3270]	225 [3270]	220 [3190]	175 [2540]
	peak**	225 [3270]	225 [3270]	225 [3270]	225 [3270]	200 [2900]
Max. Oil Flow lpm [GPM]	cont.	75 [20]	75 [20]	75 [20]	75 [20]	75 [20]
	Int.*	90 [24]	90 [24]	90 [24]	90 [24]	90 [24]
Max. Inlet Pressure bar [PSI]	cont.	210 [3045]	210 [3045]	210 [3045]	210 [3045]	210 [3045]
	Int.*	250 [3625]	250 [3625]	250 [3625]	250 [3625]	250 [3625]
	peak**	300 [4350]	300 [4350]	300 [4350]	300 [4350]	300 [4350]
Max. Return Pressure with Drain Line bar [PSI]	cont.	140 [2030]	140 [2030]	140 [2030]	140 [2030]	140 [2030]
	Int.*	175 [2540]	175 [2540]	175 [2540]	175 [2540]	175 [2540]
	peak**	210 [3045]	210 [3045]	210 [3045]	210 [3045]	210 [3045]
Max. Starting Pressure with Unloaded Shaft, bar [PSI]	10 [145]	10 [145]	10 [145]	10 [145]	10 [145]	
Min. Starting Torque daNm [in- lb]	36,9 [3270]	46,2 [4090]	58,0 [5135]	73,8 [6530]	72,0 [6370]	
Min. Speed***, [RPM]	6	6	6	5	5	

* Intermittent operation: the permissible values may occur for max. 10% of every minute.

** Peak load: the permissible values may occur for max. 1% of every minute.

*** For speeds lower than given, consult factory or your regional manager.

1. Intermittent speed and intermittent pressure must not occur simultaneously.
2. Recommended filtration is per ISO cleanliness code 20/16. A nominal filtration of 25 micron or better.
3. Recommend using a premium quality, anti-wear type mineral based hydraulic oil HLP(DIN51524) or HM (ISO 6743/4).
If using synthetic fluids consult the factory for alternative seal materials.
4. Recommended minimum oil viscosity 13 mm²/s [70 SUS] at 50°C [122°F].
5. Recommended maximum system operating temperature is 82°C [180°F].
6. To assure optimum motor life fill with fluid prior to loading and run at moderate load and speed for 10-15 minutes.

DIMENSIONS AND MOUNTING DATA

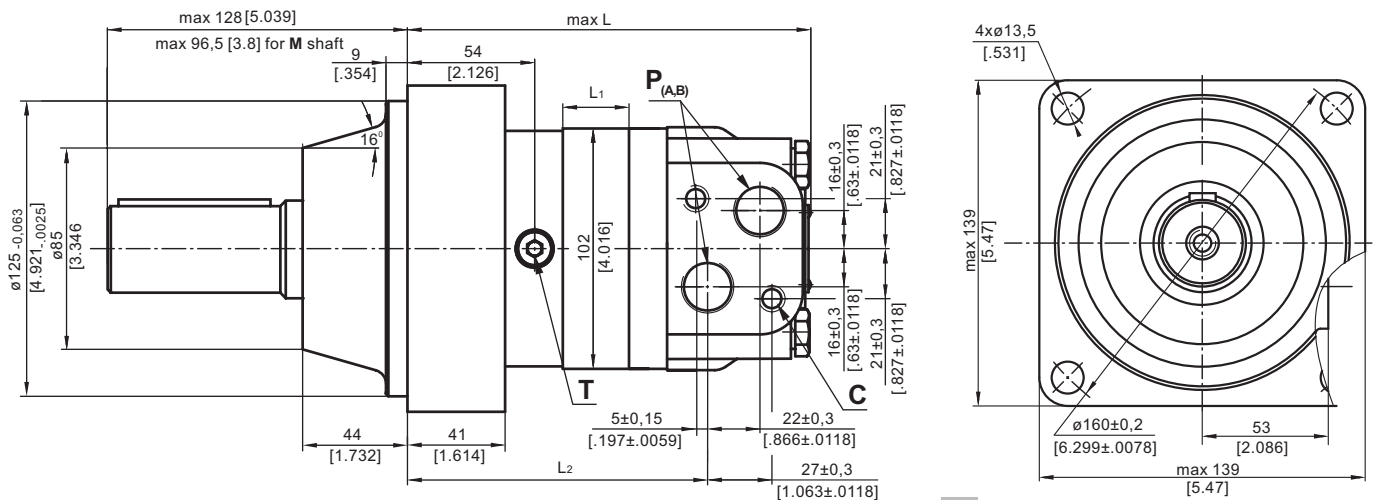

C: 2xM10-12 mm [.47 in] depth
P_(A,B): 2xG1/2 or 2xM22x1,5-15 mm [.59 in] depth
T: G ¼ or M14x1,5- 12 mm [.47 in] depth (plugged)

E Rear Ports

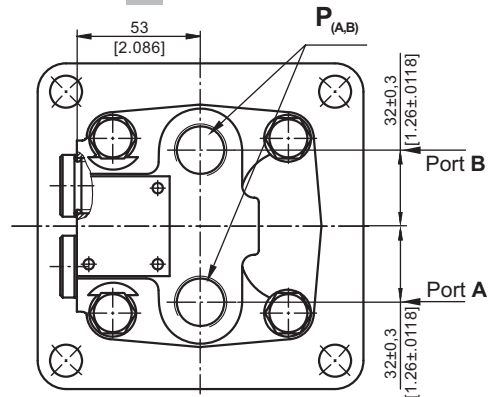

Type	L, mm[in.]	L2, mm[in.]	L1, mm[in.]
MSWM 160	170,5[6.71]	129,3[5.09]	27,8 [1.09]
MSWME 160	177,5[6.99]		
MSWM 200	177,5[6.99]	136,3[5.37]	34,8 [1.37]
MSWME 200	184,5[7.26]		
MSWM 250	186,0[7.32]	145,0[5.71]	43,5 [1.71]
MSWME 250	193,0[7.60]		
MSWM 315	197,5[7.78]	157,3[6.19]	54,8 [2.16]
MSWME 315	206,5[8.13]		
MSWM 400	212,0[8.35]	171,0[6.73]	69,4 [2.73]
MSWME 400	219,0[8.62]		

Standard Rotation Viewed from Shaft End
 Port A Pressurized - CW
 Port B Pressurized - CCW

Reverse Rotation Viewed from Shaft End
 Port A Pressurized - CCW
 Port B Pressurized - CW

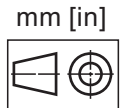

PERMISSIBLE SHAFT LOADS

The output shaft runs in tapered bearings that permit high axial and radial forces. Curve "1" shows max. radial shaft load at bearing life of 2000 hours at 100 RPM. Curve "2" shows max. radial shaft load at bearing life of 3000 hours at 200 RPM.

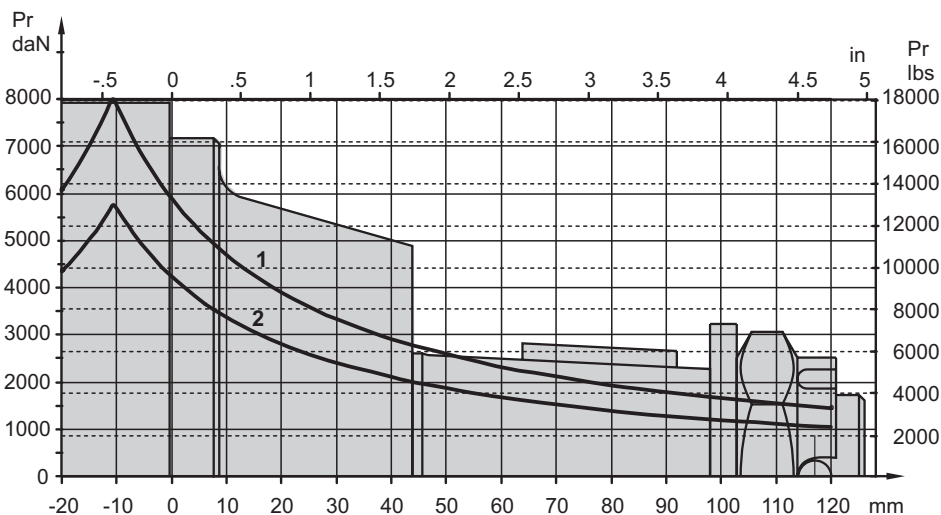

SHAFT EXTENSIONS

C - \varnothing 40 straight, Parallel key A12x8x70 DIN 6885
Max. Torque 132,8 daNm [11755 In-in]

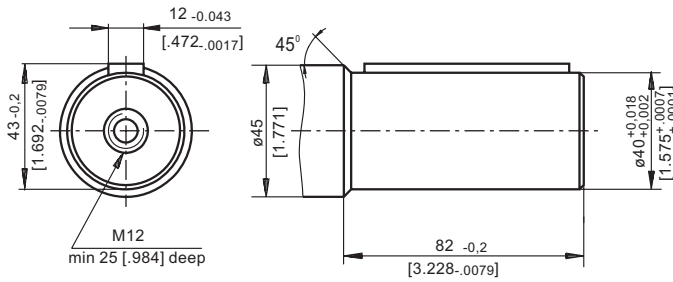

K -tapered 1:10, Parallel key B12x8x28 DIN 6885
Max. Torque 210,7 daNm [18650 lb-in]

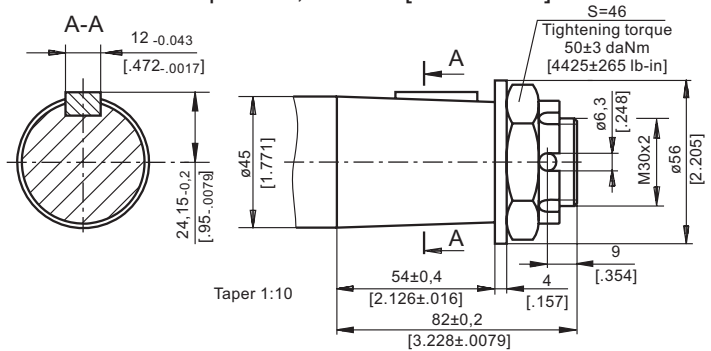

CO - \varnothing 1½" straight, Parallel key 3/8"x 3/8"x 2¼" BS46
Max. Torque 132,8 daNm [11755 In-in]

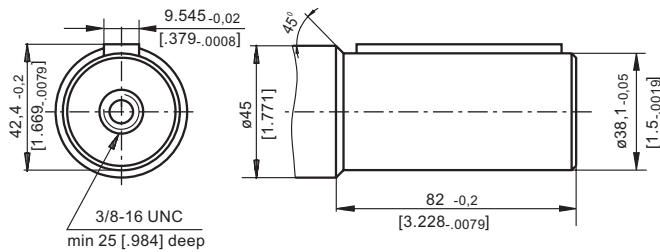

SH - \varnothing 1½" splined 17T, DP 12/24 ANSI B92.1-1976
Max. Torque 132,8 daNm [11755 In-in]

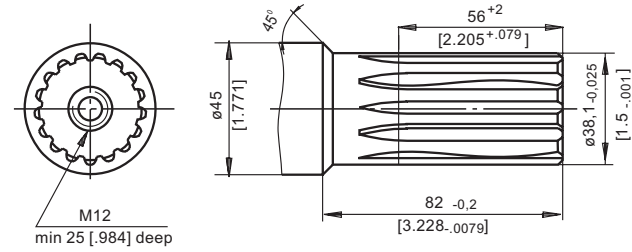

M - \varnothing 1½" splined 17T, DP 12/24 ANSI B92.1-1976
Max. Torque 132,8 daNm [11755 In-in]

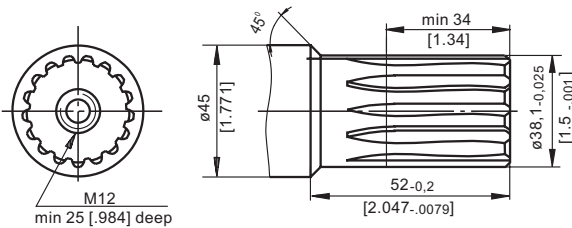

ORDER CODE

	1	2	3	4	5	6
M S W M						

Pos.1 - Port type

omit - Side ports

E - Rear ports

Pos.2 - Displacement code

160 - 159,7 cm³/rev [9.74 in³/rev]

200 - 200,0 cm³/rev [12.20 in³/rev]

250 - 250,0 cm³/rev [15.30 in³/rev]

315 - 314,9 cm³/rev [19.20 in³/rev]

400 - 397,0 cm³/rev [24.20 in³/rev]

Pos.4 - Shaft Extensions*

C - \varnothing 40 straight, Parallel key A12x8x70 DIN6885

CO - \varnothing 1½" straight, Parallel key 3/8"x 3/8"x 2¼" BS46

K - \varnothing 45 tapered 1:10, Parallel key B12x8x28 DIN6885

SH - \varnothing 1½" splined 17T ANS B92.1-1976

M - \varnothing 1½" splined 17T ANS B92.1-1976

Pos. 4 - Ports

omit - BSPP (ISO 228)

M - Metric (ISO 262)

Pos. 5 - Special Features (see page 34)

Pos. 6 - Design Series

omit - Factory specified

NOTES:

* The permissible output torque for shafts must not be exceeded!

The hydraulic motors are mangano-phosphatized as standard.

HYDRAULIC MOTORS MTM



APPLICATION

- » Skid Steer Loaders
- » Metal working machines
- » Trenchers
- » Augers
- » Agriculture machines
- » Road building machines
- » Special vehicles
- » Mine machines
- » Woodworking and sawmill machinery
- » Conveyors etc.

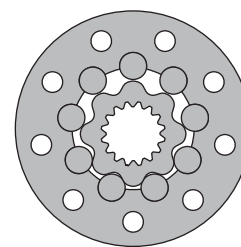
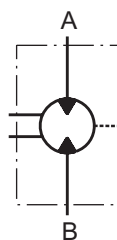

CONTENTS

Specification data	9
Function diagrams	10÷12
Dimensions and mounting	13÷15
Shaft extensions	16
Permissible shaft loads	16
Dimensions and mounting- MTMV	17
Dimensions and mounting- MTM6V	18
Internal Spline data	19
Order code	19

OPTIONS

- » Model- Disc valve, roll-gerotor
- » Flange with wheel mount
- » Short motor
- » Side ports
- » Shafts- straight, splined and tapered
- » BSPP ports;
- » Other special features.

EXCELLENCE

- » High torque and pressure drop
- » High inlet pressure
- » High starting torque
- » Improved efficiency at high pressure drop
- » Smooth operation at low speed

GENERAL

Max. Displacement, cm ³ /rev [in ³ /rev]	724,3 [44.2]
Max. Speed, [RPM]	750
Max. Torque, daNm [in-lb]	cont.: 183 [16200] int.: 229 [20270]
Max. Output, kW [HP]	70 [94]
Max. Pressure Drop, bar [PSI]	cont.: 250 [3600] int.: 350 [5080]
Max. Oil Flow, lpm [GPM]	150 [40]
Min. Speed, [RPM]	5
Permissible Shaft Loads daN [lbs]	P _a =1000 [2250]
Pressure fluid	Mineral based- HLP(DIN 51524) or HM(ISO 6743/4)
Temperature range, °C [°F]	-40÷140 [-40÷284]
Optimal Viscosity range, mm ² /s [SUS]	20÷75 [98÷347]
Filtration	ISO code 20/16 (Min. recommended fluid filtration of 25 micron)

Oil flow in drain line

Pressure drop bar [PSI]	Viscosity mm ² /s [SUS]	Oil flow in drain line lpm [GPM]
200 [2900]	20 [98]	2,5 [.660]
	35 [164]	1,5 [.400]
275 [3990]	20 [98]	4 [1.057]
	35 [164]	2,5 [.660]

Pressure Losses

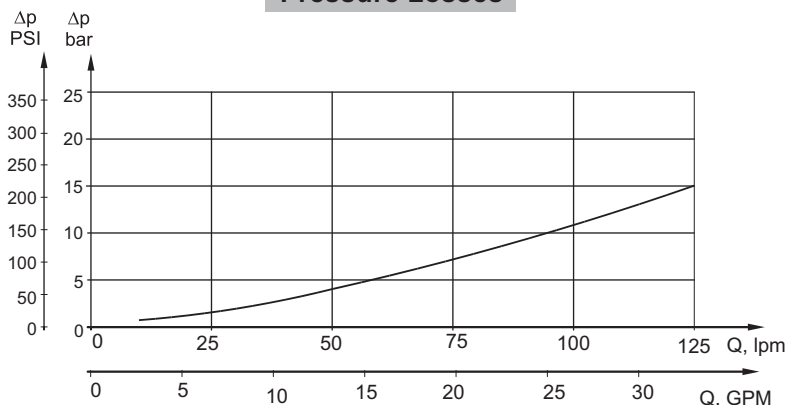

SPECIFICATION DATA

Type		MTM 200	MTM 250	MTM 315	MTM 400	MTM 470	MTM 500	MTM 630	MTM 725
Displacement, cm³/rev [in³/rev]		201,4 [12.29]	251,8 [15.36]	326,3 [19.9]	410,9 [25.06]	475 [28.97]	523,6 [31.95]	631,2 [38.52]	724 [44.2]
Max. Speed, [RPM]	Cont.	625	500	380	305	260	240	190	170
	Int.*	750	600	460	365	315	285	230	215
Max. Torque daNm [in-lb]	Cont.	72[6375]	90[7965]	116[10265]	147[13010]	171[15135]	172[15225]	183[16200]	160[14160]
	Int.*	102[9030]	128[11330]	163[14425]	206[18232]	215[16030]	215[16030]	229[20270]	192[17000]
	Peak**	115[10180]	144[12745]	186[16460]	235[20800]	240[21240]	240[21240]	274[24250]	240[21240]
Max. Output kW [HP]	Cont.	41 [55]	41 [55]	41 [55]	41 [55]	41 [55]	37,5[50]	28 [37,5]	26 [35]
	Int.*	70[94]	70[94]	70[94]	70[94]	55[74]	51 [68]	42 [56]	40 [54]
Max. Pressure Drop bar [PSI]	Cont.	250[3600]	250[3600]	250[3600]	250[3600]	250[3600]	230[3340]	200[2900]	160[2320]
	Int.*	350[5080]	350[5080]	350[5080]	350[5080]	315[4570]	280[4060]	250[3625]	210[3045]
	Peak**	400[5800]	400[5800]	400[5800]	400[5800]	350[5080]	320[4640]	300[4350]	260[3770]
Max. Oil Flow lpm [GPM]	Cont.	125[33]	125[33]	125[33]	125[33]	125[33]	125[33]	125[33]	125[33]
	Int.*	150[40]	150[40]	150[40]	150[40]	150[40]	150[40]	150[40]	150[40]
Max. Inlet Pressure bar [PSI]	Cont.	270[3920]	270[3920]	270[3920]	270[3920]	270[3920]	270[3920]	270[3920]	270[3920]
	Int.*	370[5370]	370[5370]	370[5370]	370[5370]	370[5370]	370[5370]	370[5370]	370[5370]
	Peak**	420[6100]	420[6100]	420[6100]	420[6100]	420[6100]	420[6100]	420[6100]	420[6100]
Max. Return Pressure without Drain Line or Max. Pressure in Drain Line, bar [PSI]	Cont. 0-100 RPM	75 [1100]	75 [1100]	75 [1100]	75 [1100]	75 [1100]	75 [1100]	75 [1100]	75 [1100]
	Cont. 100-300 RPM	40 [580]	40 [580]	40 [580]	40 [580]	40 [580]	40 [580]	40 [580]	40 [580]
	Cont. >300 RPM	20 [290]	20 [290]	20 [290]	20 [290]	20 [290]	-	-	-
	Int.* 0-max. RPM	75 [1100]	75 [1100]	75 [1100]	75 [1100]	75 [1100]	75 [1100]	75 [1100]	75 [1100]
Max. Return Pressure with Drain Line bar [PSI]	Cont.	270 [3920]	270 [3920]	270 [3920]	270 [3920]	270 [3920]	270 [3920]	270 [3920]	270 [3920]
	Int.*	370 [5370]	370 [5370]	370 [5370]	370 [5370]	370 [5370]	370 [5370]	370 [5370]	370 [5370]
	Peak**	420 [6100]	420 [6100]	420 [6100]	420 [6100]	420 [6100]	420 [6100]	420 [6100]	420 [6100]
Max. Starting Pressure with Unloaded Shaft, bar [PSI]		6 [90]	6 [90]	6 [90]	6 [90]	6 [90]	6 [90]	6 [90]	6 [90]
Min. Starting Torque daNm [in-lb]		60[5310]	75[6640]	97[8585]	122[10800]	142[12570]	143[12655]	145[12830]	148[13100]
Min. Speed***, [RPM]		5	5	5	5	5	5	5	5
Weight, kg [lb]	MTM	26,9 [59.3]	27,3 [60.2]	28,1 [62]	29 [64]	29,7 [65.5]	30,2 [66.6]	29,7 [65.5]	31 [68.4]
	MTMW	27,4 [60.4]	27,8 [61.3]	28,6 [63.1]	29,5 [65.1]	30,2 [66.6]	30,7 [67.7]	30,2 [66.6]	31,5 [69.5]
	MTMV	15,7 [34.6]	16,1 [35.5]	16,9 [37.3]	17,8 [39.3]	18,5 [40.8]	19 [41.9]	18,5 [40.8]	19,8 [43.7]

* Intermittent operation: the permissible values may occur for max. 10% of every minute.

** Peak load: the permissible values may occur for max. 1% of every minute.

*** For speeds of 5 RPM lower than given, consult factory or your regional manager.

- Intermittent speed and intermittent pressure must not occur simultaneously.
- Recommended filtration is per ISO cleanliness code 20/16. A nominal filtration of 25 micron or better.
- Recommend using a premium quality, anti-wear type mineral based hydraulic oil, HLP(DIN51524) or HM(ISO6743/4).
If using synthetic fluids consult the factory for alternative seal materials.
- Recommended minimum oil viscosity 70 SUS [13 mm²/s] at 50°C [122°F].
- Recommended maximum system operating temperature is 82°C [180°F].
- To assure optimum motor life fill with fluid prior to loading and run at moderate load and speed for 10-15 minutes.

FUNCTION DIAGRAMS

MTM 250

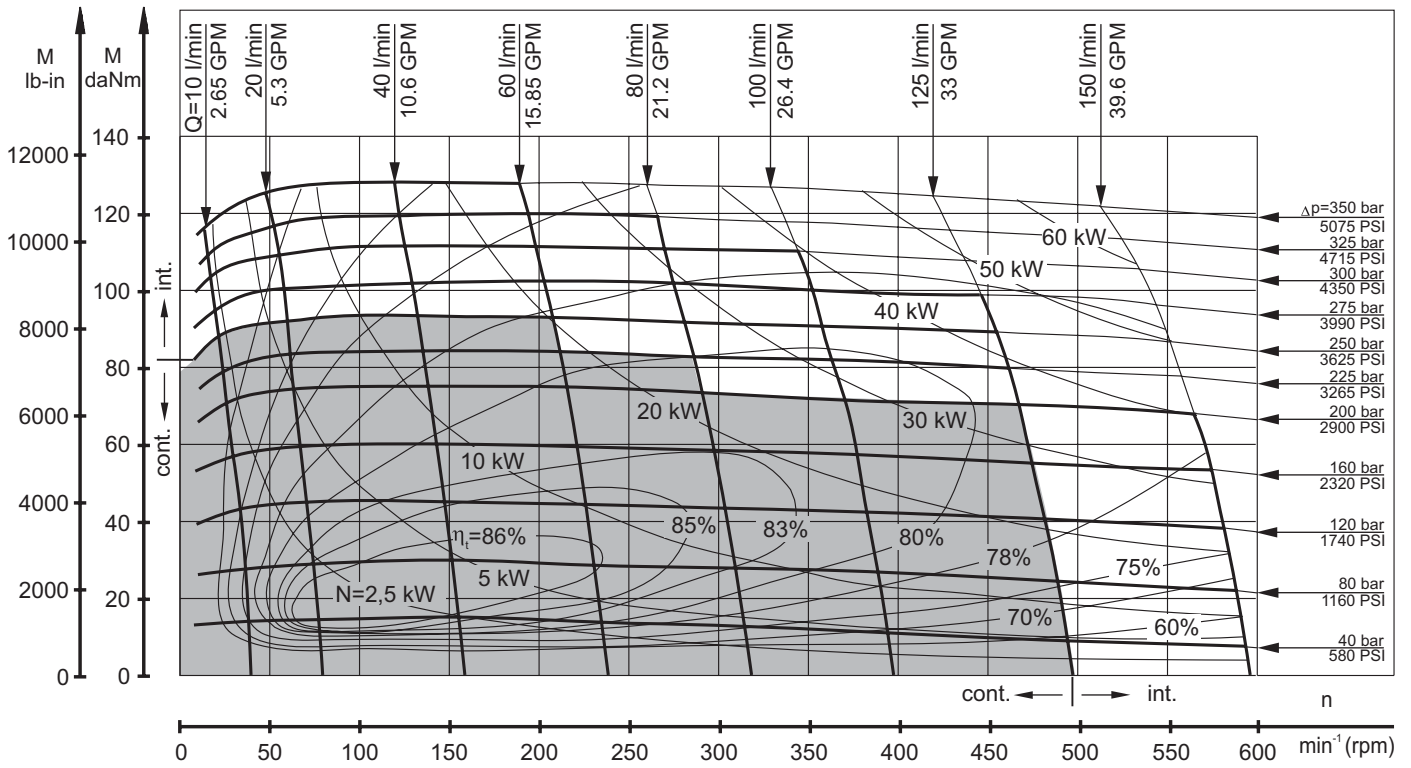

MTM 315

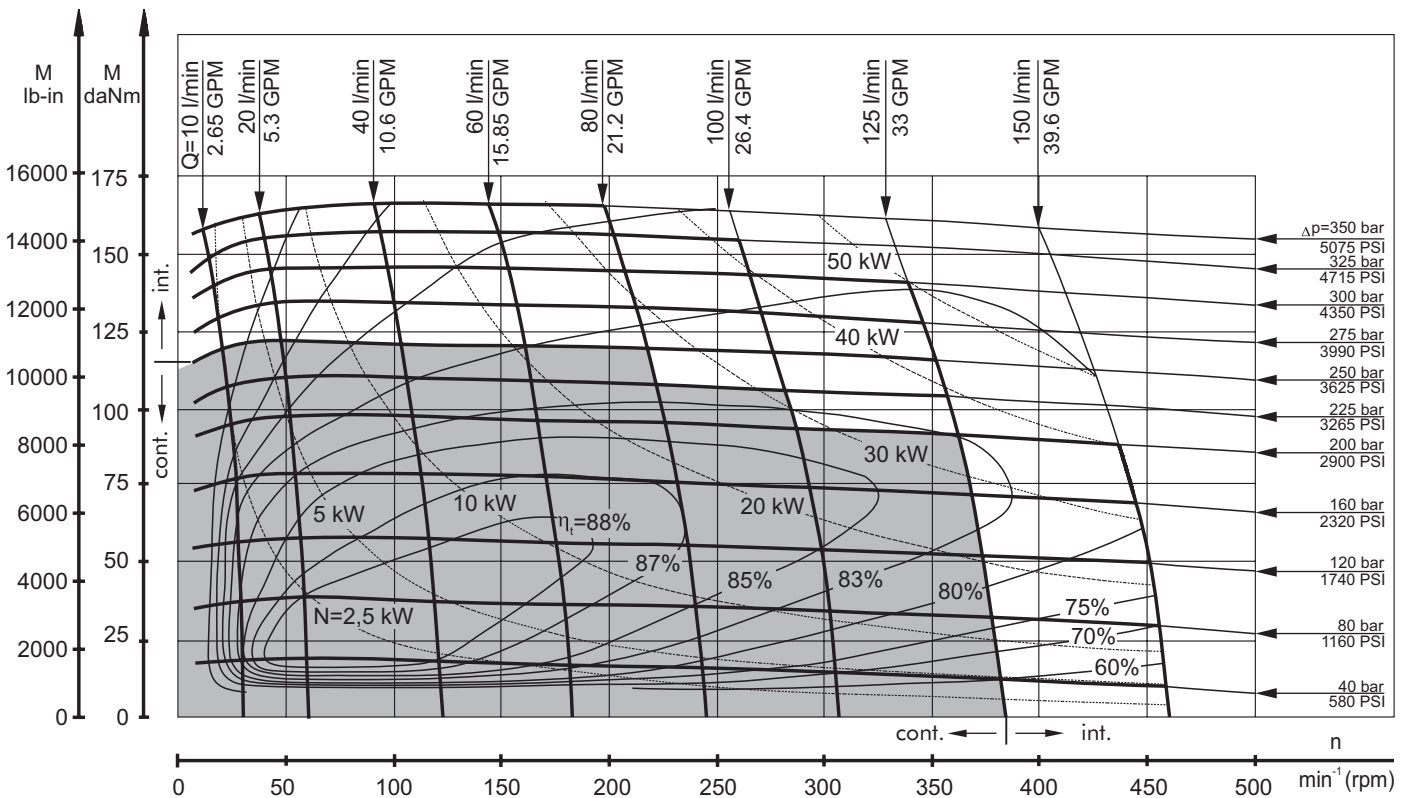

The function diagrams data was collected at back pressure 5÷10 bar (72.5PSI÷145PSI) and oil with viscosity of 32 mm²/s [150SUS] at 50° C [122°F].

FUNCTION DIAGRAMS

MTM 400

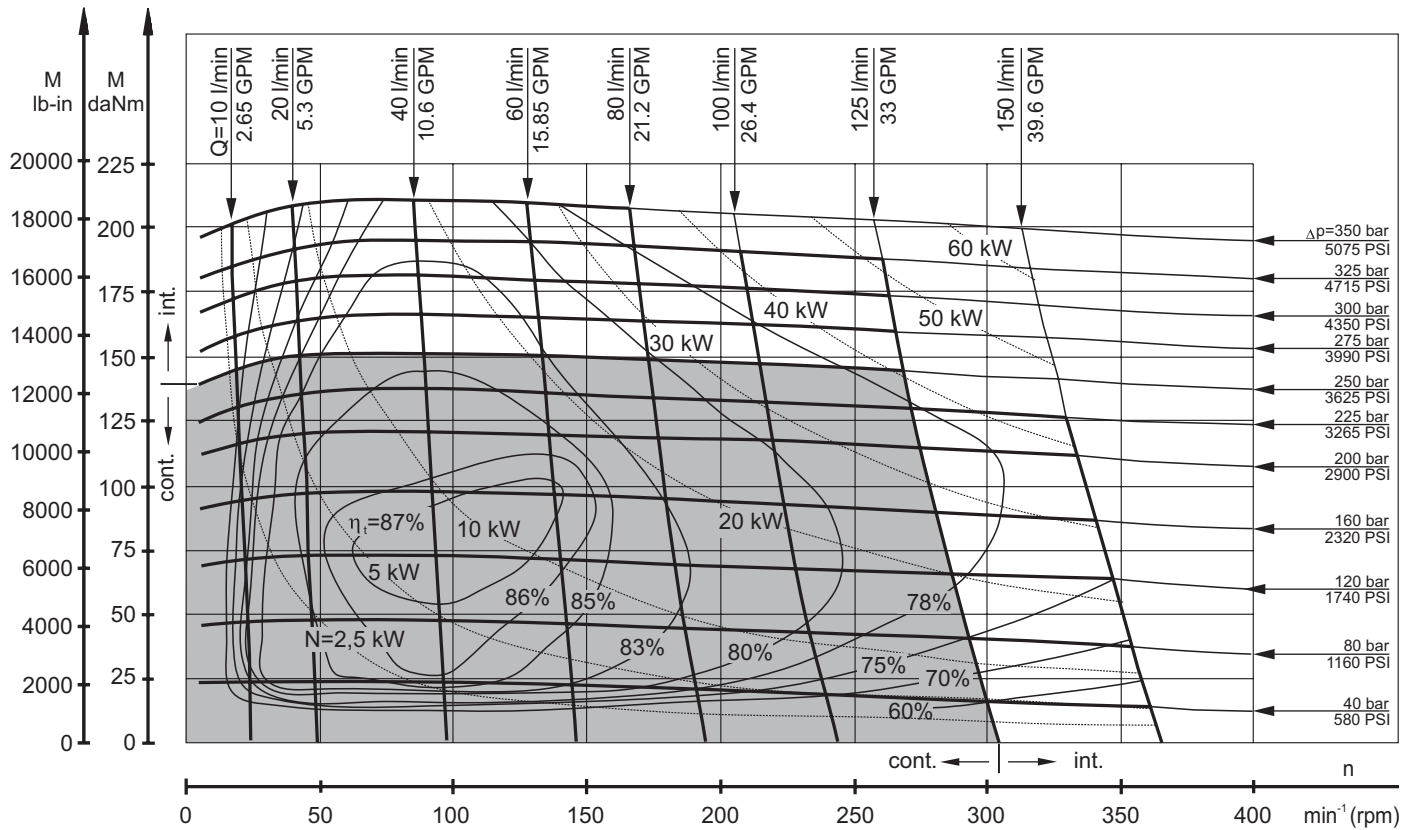

MTM 470

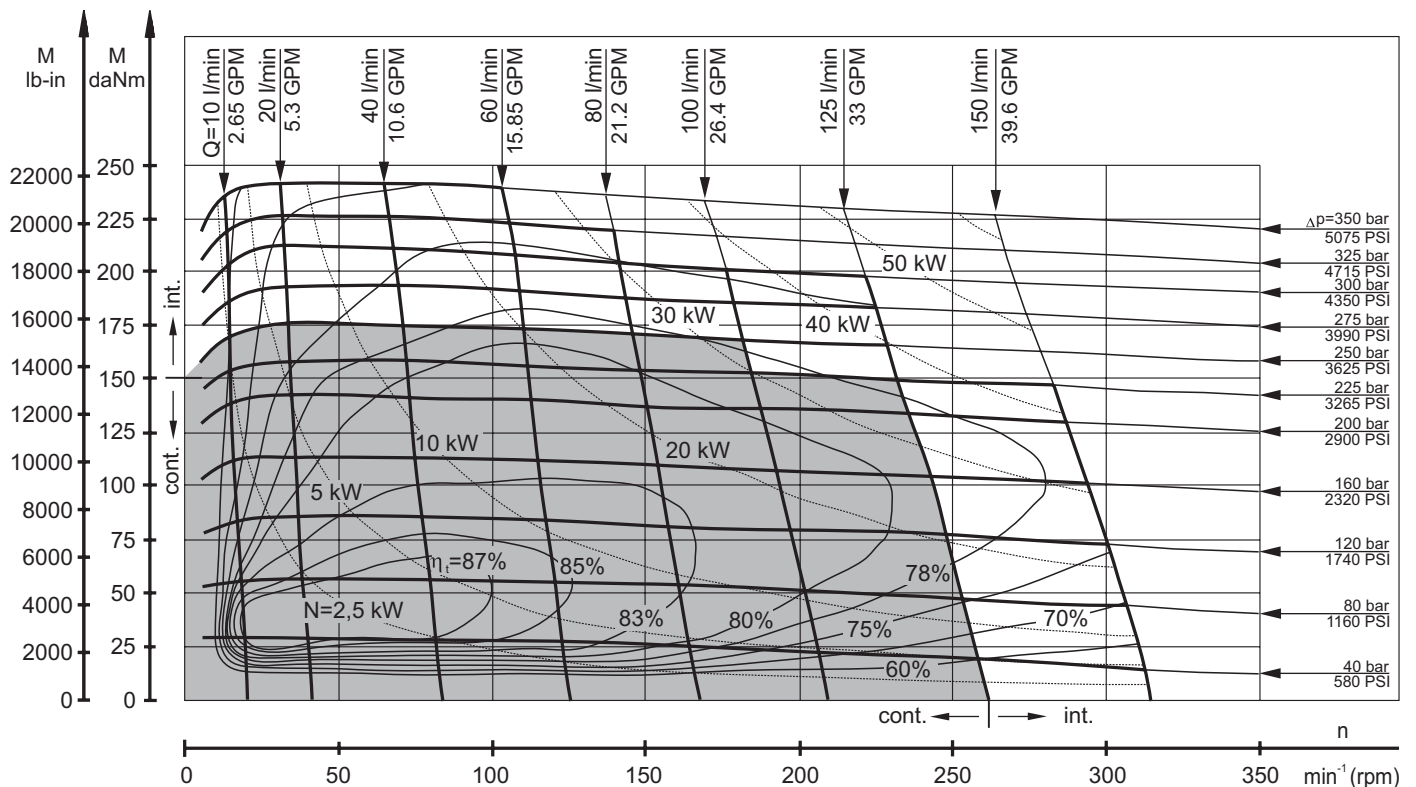

The function diagrams data was collected at back pressure 5÷10 bar (72.5PSI÷145PSI) and oil with viscosity of 32 mm²/s [150SUS] at 50° C [122°F].

FUNCTION DIAGRAMS

MTM 500

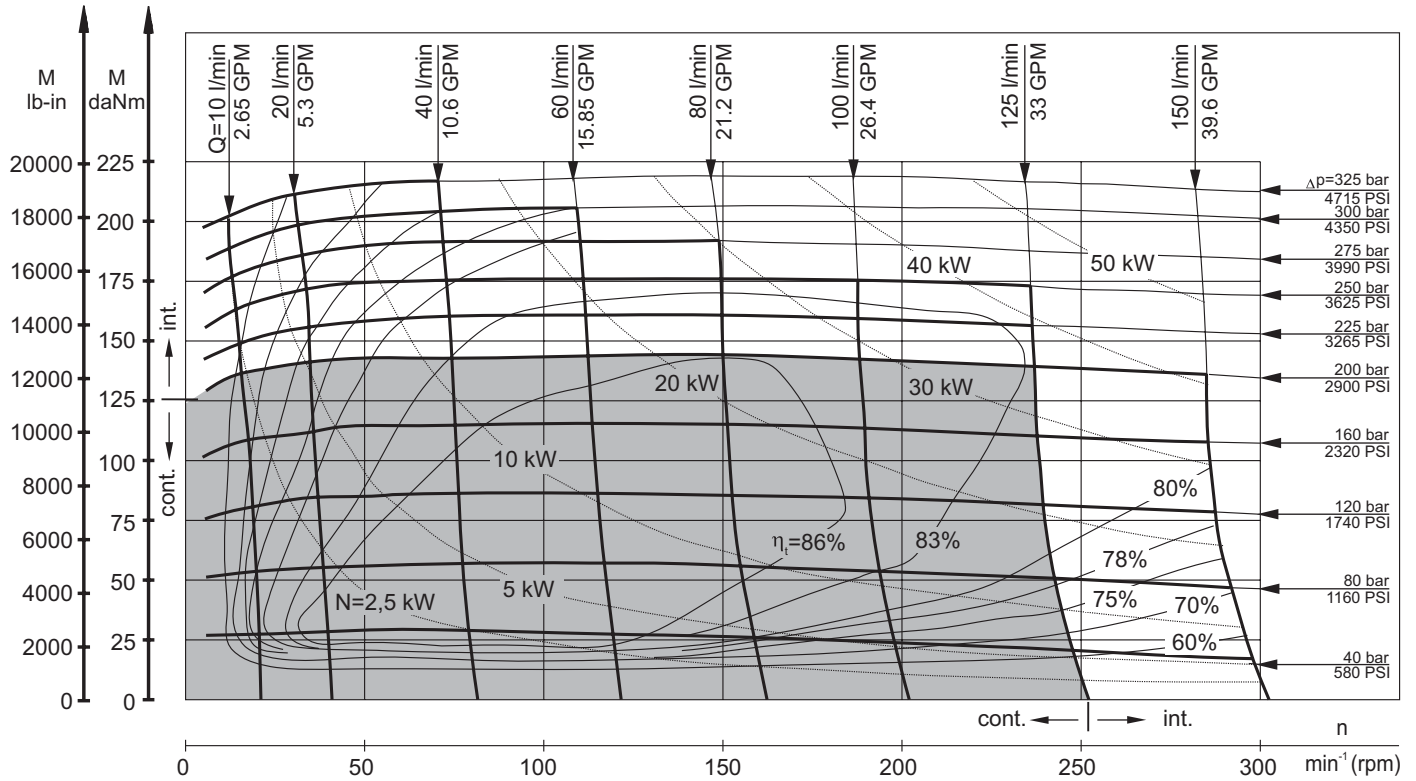

MTM 630

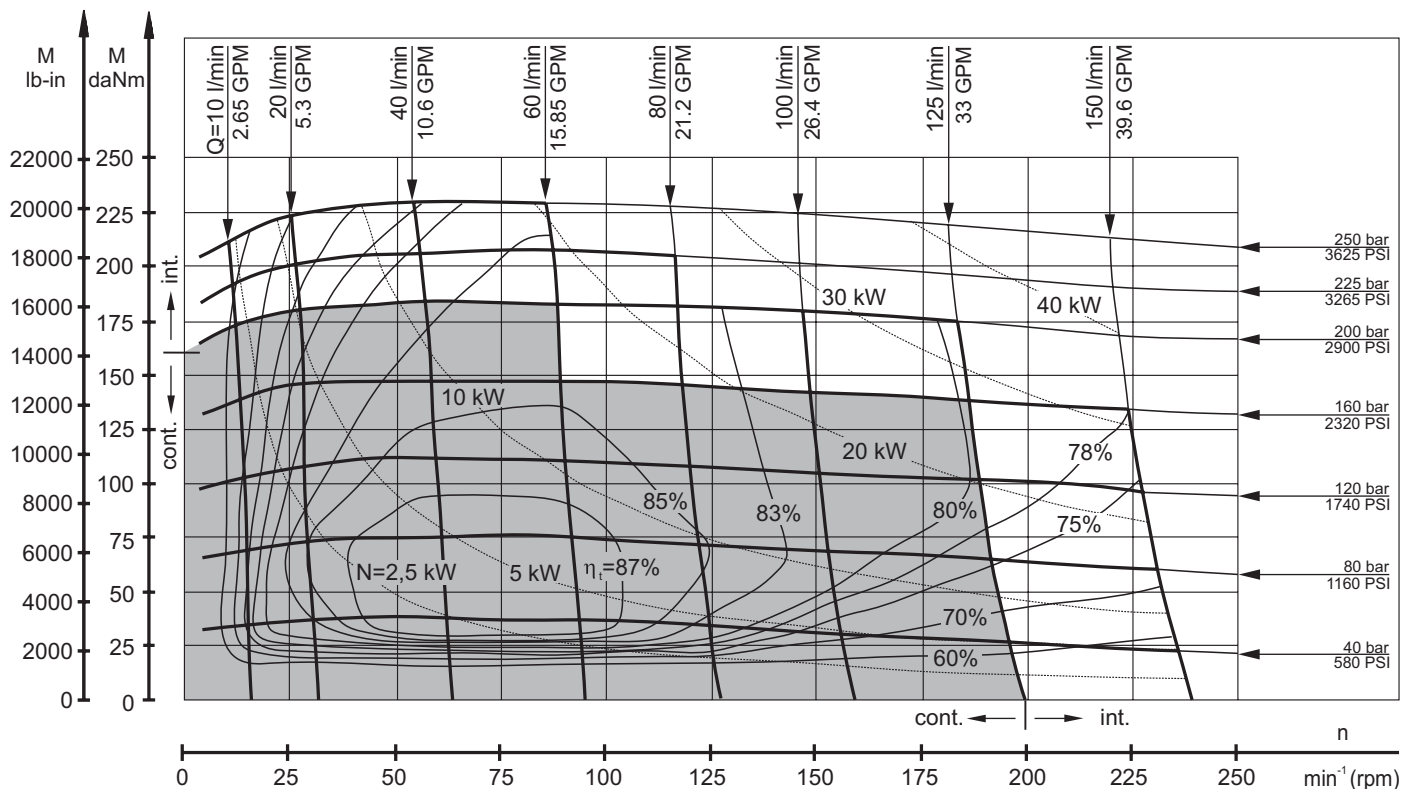

The function diagrams data was collected at back pressure 5÷10 bar (72.5PSI÷145PSI) and oil with viscosity of 32 mm²/s [150SUS] at 50° C [122°F].

DIMENSIONS AND MOUNTING DATA - MTM and MTMC

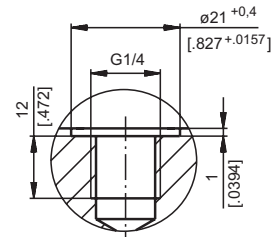
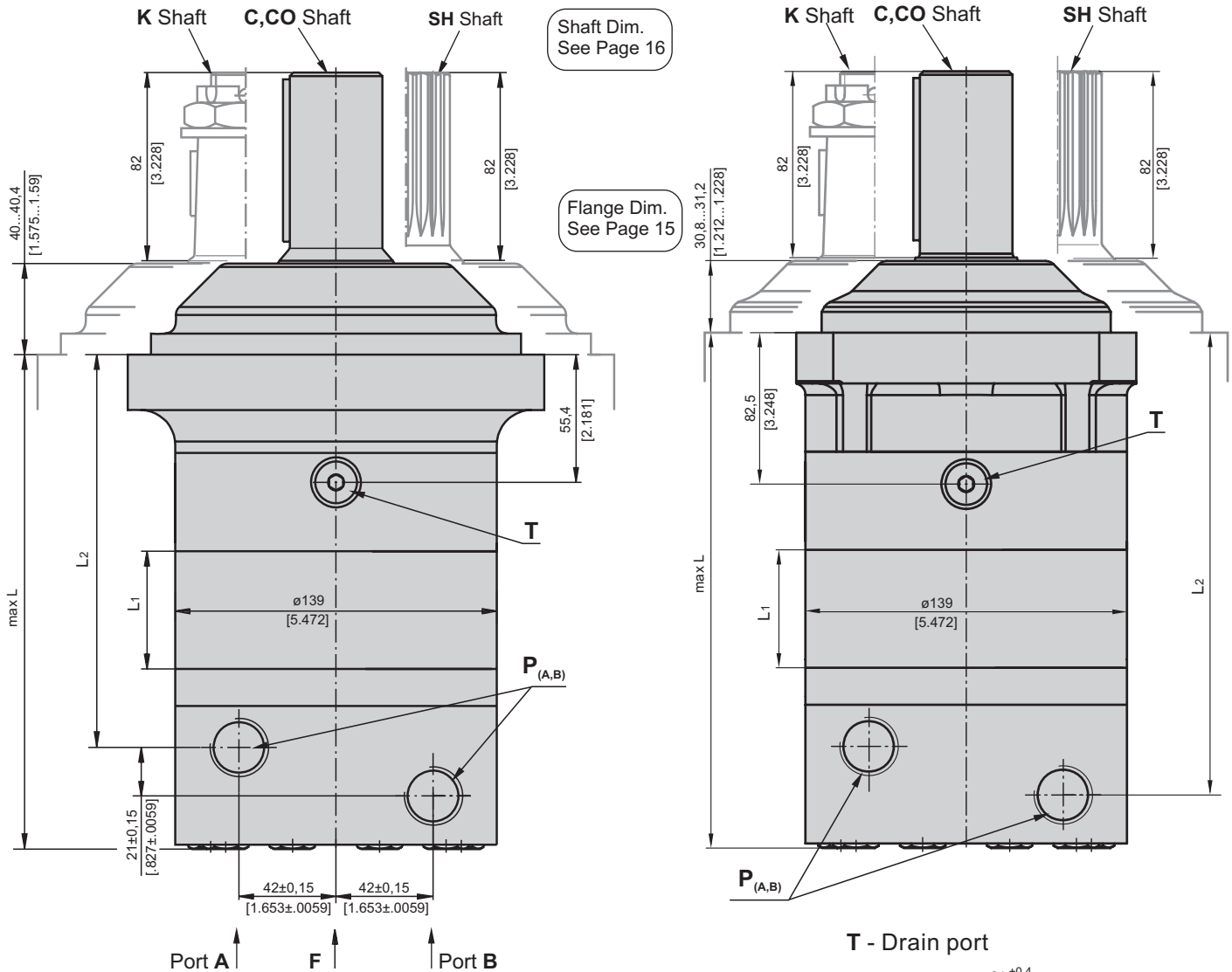

Warning: Drain line should always be used.

P_(A,B): 2xG3/4 - 17 mm [.669 in] depth
T : G1/4 - 12 mm [.472 in] depth (plugged)

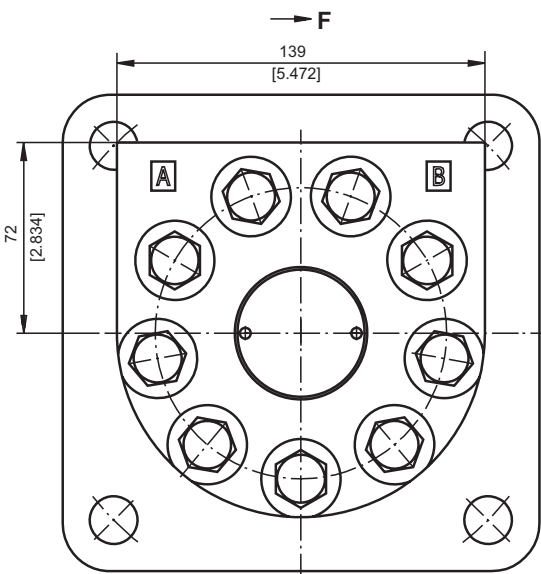

Type	L, mm [in]	L ₂ , mm [in]	Type	L, mm [in]	L ₂ , mm [in]	L ₁ , mm [in]
MTM 200	188 [7.40]	142,3 [5.60]	MTMC 200	198 [7.79]	153 [6.02]	25 [.98]
MTM 250	194 [7.64]	148,6 [5.85]	MTMC 250	204,5 [8.05]	159,3 [6.27]	31,3 [1.23]
MTM 315	203 [7.99]	157,8 [6.21]	MTMC 315	213,5 [8.40]	168,5 [6.63]	40,5 [1.59]
MTM 400	214 [8.43]	168,3 [6.63]	MTMC 400	224 [8.82]	179 [7.04]	51 [2.01]
MTM 470	222 [8.74]	176,3 [6.94]	MTMC 470	232 [9.13]	187 [7.36]	59 [2.32]
MTM 500	228 [8.98]	182,3 [7.18]	MTMC 500	238 [9.37]	193 [7.60]	65 [2.56]
MTM 630	224 [8.82]	178,3 [7.02]	MTMC 630	234 [9.21]	189 [7.44]	61 [2.40]
MTM 725	233 [9.17]	187,3 [7.37]	MTMC 725	243 [9.56]	198 [7.79]	70 [2.76]

Standard Rotation
Viewed from Shaft End
Port A Pressurized - **CW**
Port B Pressurized - **CCW**

Reverse Rotation
Viewed from Shaft End
Port A Pressurized - **CCW**
Port B Pressurized - **CW**



DIMENSIONS AND MOUNTING DATA - MTMW

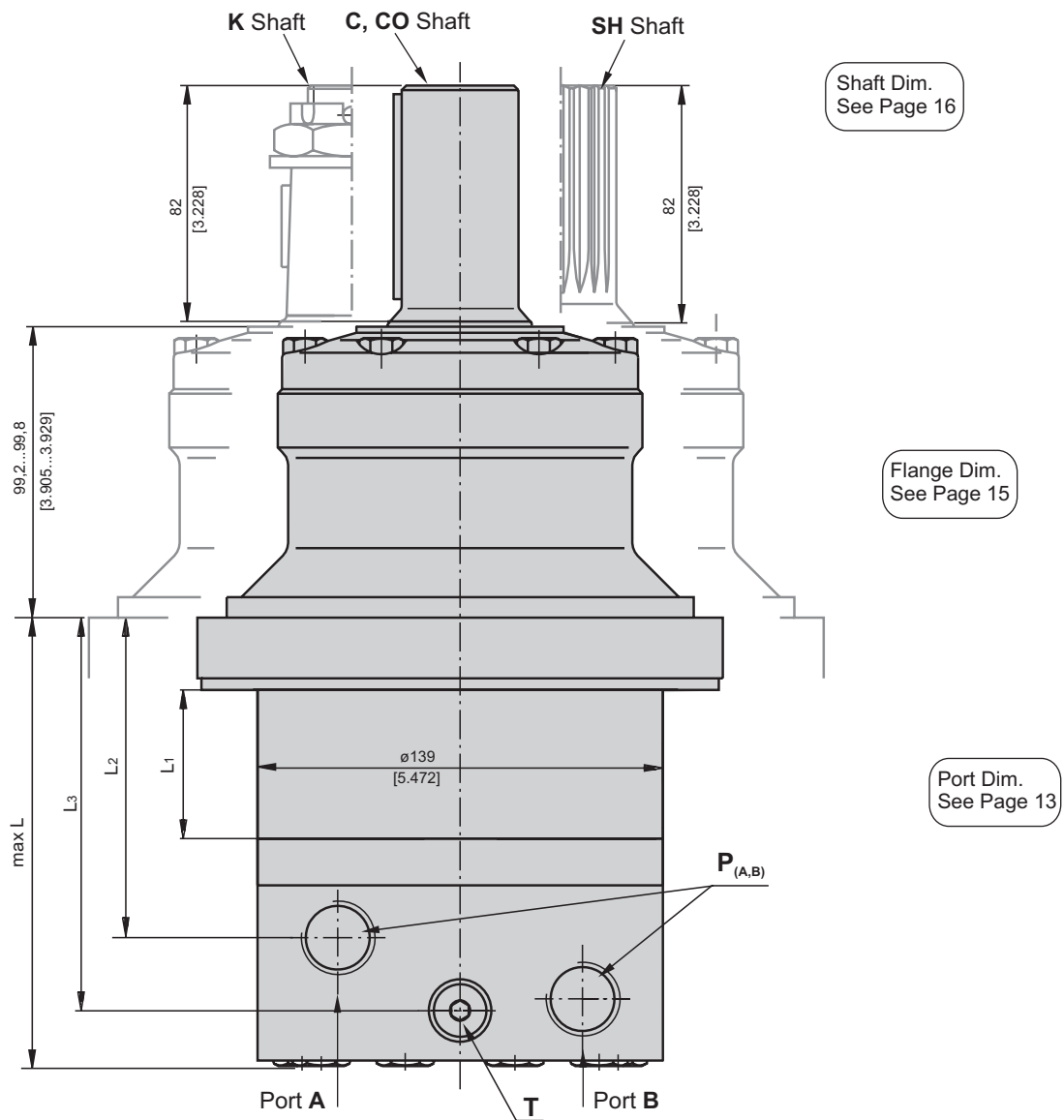

Warning: Drain line should always be used.

P_(A,B): 2xG3/4 - 17 mm [.669 in] depth
T : G1/4 - 12 mm [.472 in] depth (plugged)

Type	L, mm [in]	L ₁ , mm [in]	L ₂ , mm [in]	L ₃ , mm [in]
MTMW 200	129 [5.08]	25 [.98]	83,8 [3.30]	111,1 [3.37]
MTMW 250	135 [5.32]	31,3 [1.23]	90,1 [3.55]	117,4 [4.62]
MTMW 315	144 [5.67]	40,5 [1.59]	99,3 [3.91]	126,6 [4.98]
MTMW 400	155 [6.10]	51 [2.01]	109,8 [4.32]	137,1 [5.40]
MTMW 470	163 [6.42]	59 [2.32]	117,8 [4.64]	145,1 [5.71]
MTMW 500	169 [6.65]	65 [2.56]	123,8 [4.87]	151,1 [5.95]
MTMW 630	165 [6.50]	61 [2.40]	119,8 [4.72]	147,1 [5.79]
MTMW 725	174 [6.85]	70 [2.76]	128,8 [5.07]	156,1 [6.15]

Standard Rotation
 Viewed from Shaft End
 Port **A** Pressurized - **CW**
 Port **B** Pressurized - **CCW**

Reverse Rotation
 Viewed from Shaft End
 Port **A** Pressurized - **CCW**
 Port **B** Pressurized - **CW**



MOUNTING

4-Bolt flange
spigot diameter $\varnothing 160$ mm [6.3 in] - BC $\varnothing 200$ [7.874 in] mm

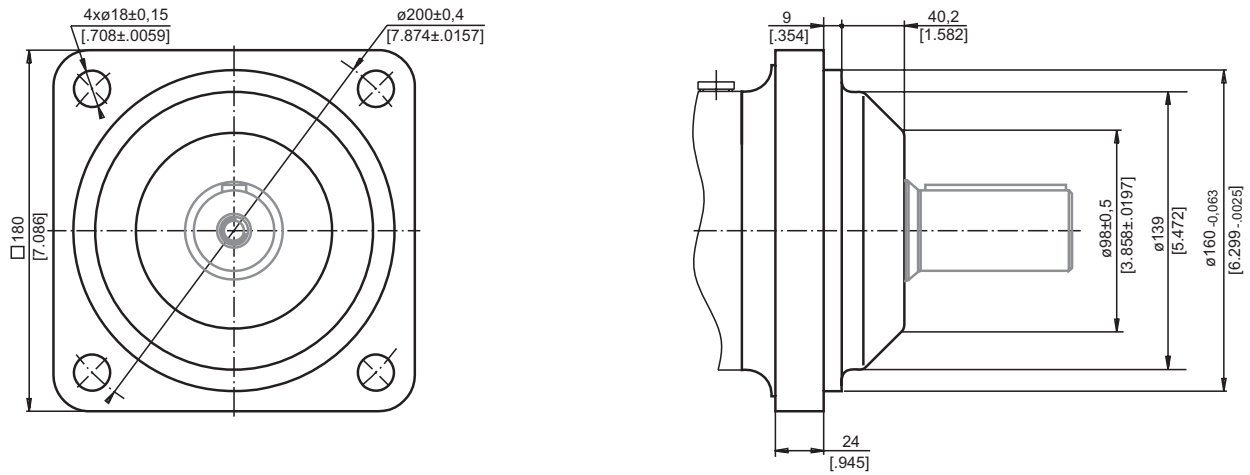

C 4-Bolt flange
spigot diameter $\varnothing 125$ mm [4.921 in] - BC $\varnothing 160$ mm [6.3 in]

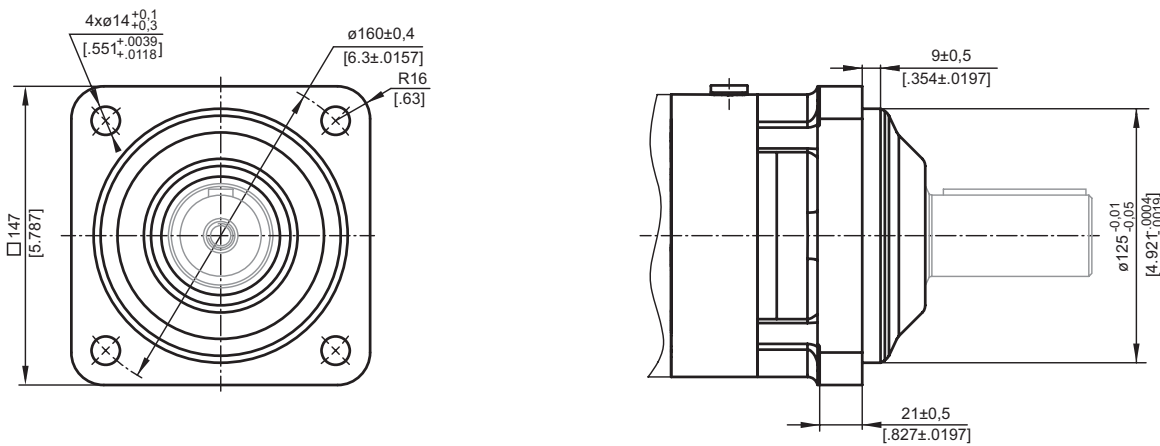

W 4-Bolt flange, Wheel Motor
spigot diameter $\varnothing 160$ mm [6.3 in] - BC $\varnothing 200$ mm [7.874 in]

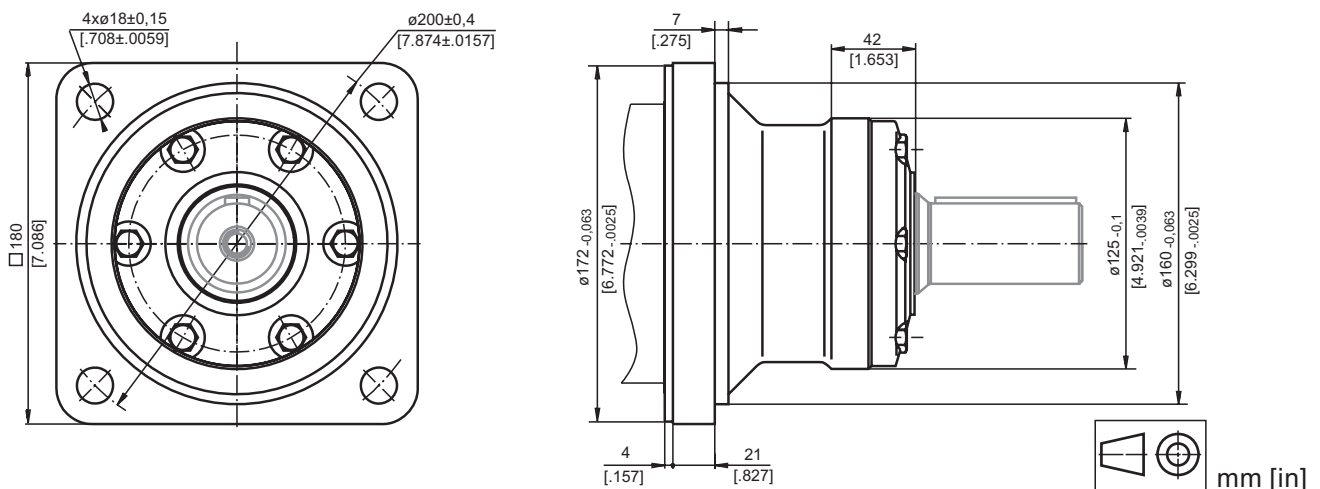

SHAFT EXTENSIONS

C - $\varnothing 40$ straight, Parallel key A12x8x70 DIN 6885
Max. Torque 132,8 daNm [11755 lb-in]

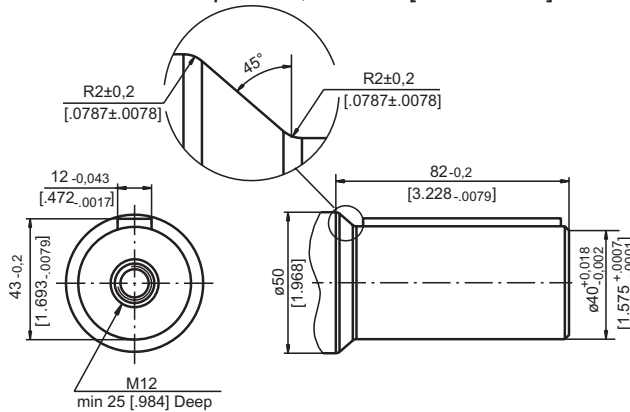

SH - $\varnothing 1\frac{1}{2}$ " splined 17T, DP 12/24 ANSI B92.1-1976
Max. Torque 132,8 daNm [11755 lb-in]

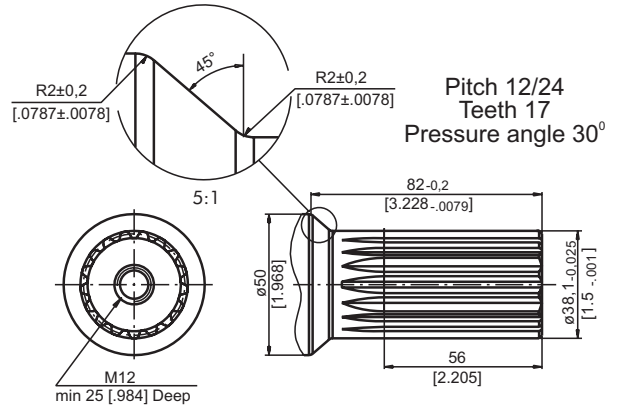

CO - $\varnothing 1\frac{1}{2}$ " straight, Parallel key $\frac{3}{8}$ "x $\frac{3}{8}$ "x $\frac{1}{4}$ " BS46
Max. Torque 132,8 daNm [11755 lb-in]

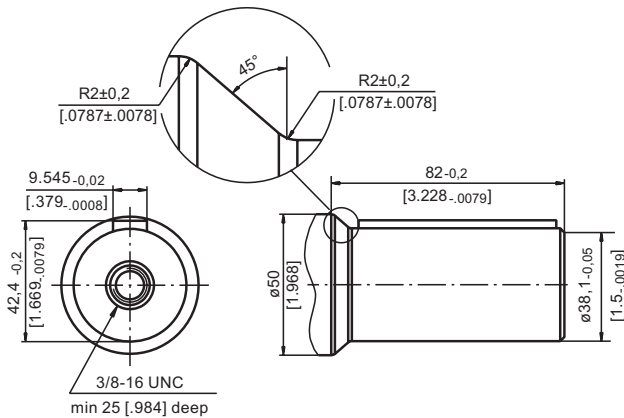

K - tapered 1:10, Parallel key B12x8x28 DIN 6885
Max. Torque 210,7 daNm [18650 lb-in]

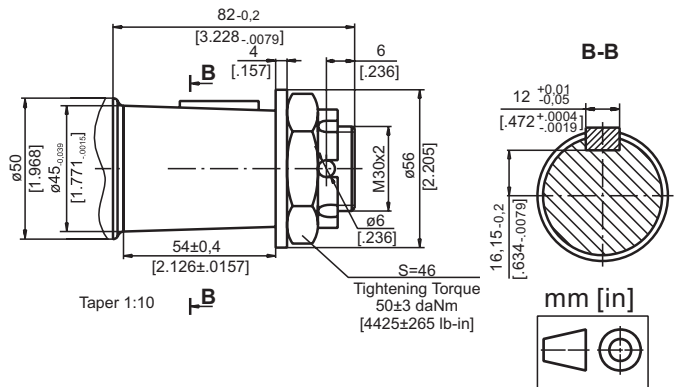

PERMISSIBLE SHAFT LOADS

The curves apply to a B10 bearing life (ISO281) of 2000 hours at 200 RPM.

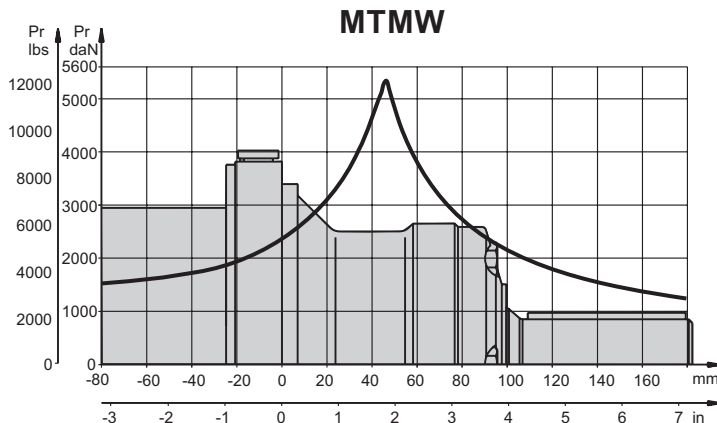
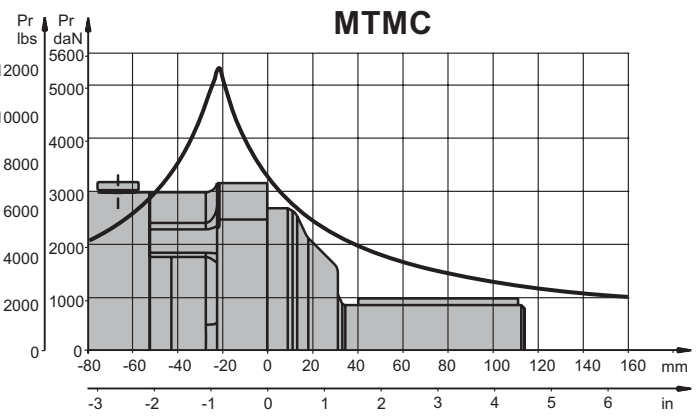
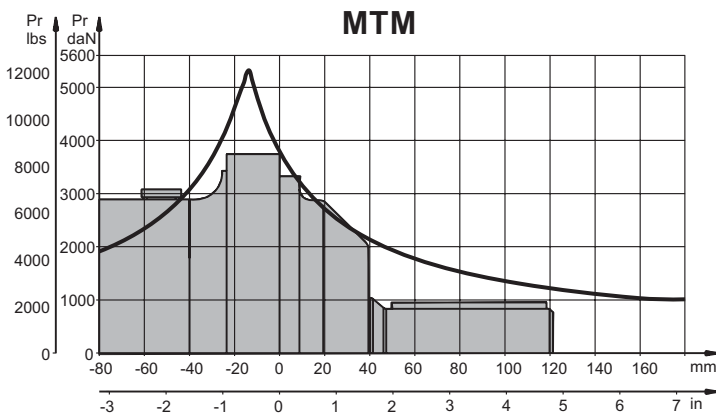

DIMENSIONS AND MOUNTING DATA - MTMV

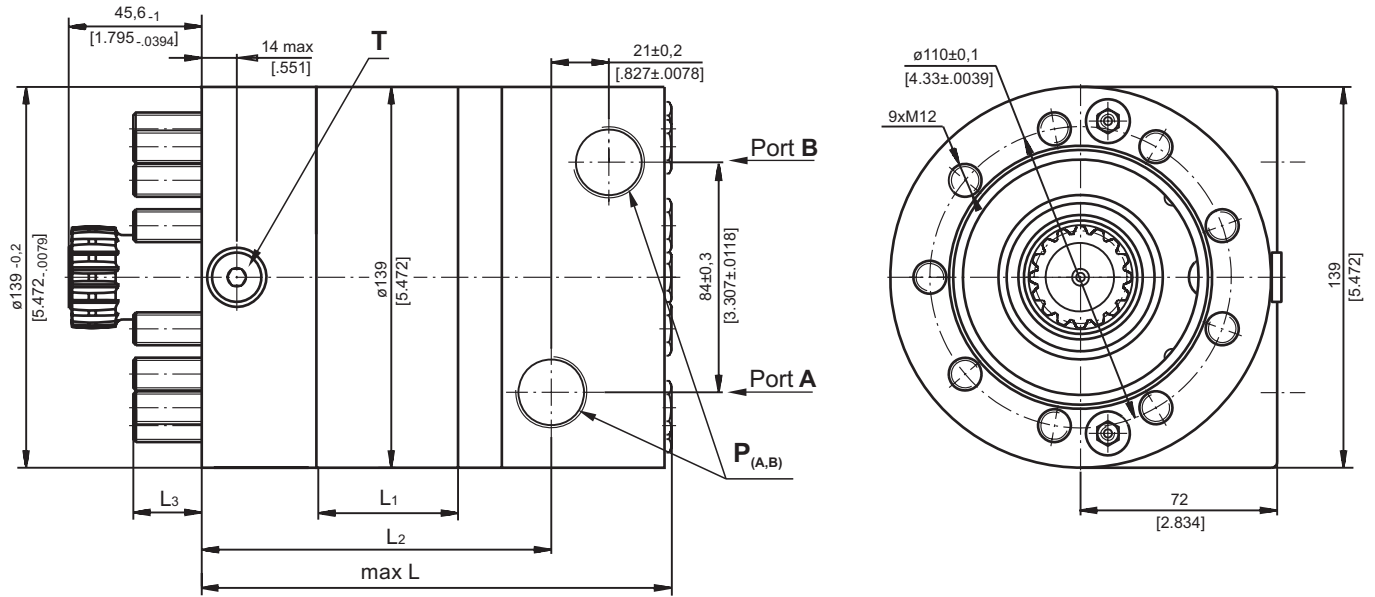

Warning: Drain line should always be used.

P_(A,B): 2xG3/4 - 17 mm [0.669 in] depth
T : G1/4 12 mm [0.472 in] depth (plugged)

Standard Rotation Viewed from Shaft End Port A Pressurized - CW Port B Pressurized - CCW	Reverse Rotation Viewed from Shaft End Port A Pressurized - CCW Port B Pressurized - CW
--	---

Type	L, mm [in]	L ₁ , mm [in]	L ₂ , mm [in]	L ₃ , mm [in]
MTMV 200	151 [5.945]	25 [.98]	106,5 [4.193]	27,8 [1.094]
MTMV 250	157 [6.181]	31,3 [1.23]	112,8 [4.441]	26,5 [1.043]
MTMV 315	167 [6.575]	40,5 [1.59]	122,0 [4.803]	22,3 [.878]
MTMV 400	177 [6.968]	51 [2.01]	132,5 [5.217]	21,8 [.858]
MTMV 470	185 [7.283]	59 [2.32]	140,5 [5.531]	23,8 [.937]
MTMV 500	191 [7.520]	65 [2.56]	146,5 [5.768]	27,8 [1.094]
MTMV 630	187 [7.362]	61 [2.40]	142,5 [5.610]	26,8 [1.055]
MTMV 725	196 [7.717]	70 [2.76]	151,5 [5.965]	27,8 [1.094]

DIMENSIONS OF THE ATTACHED COMPONENT

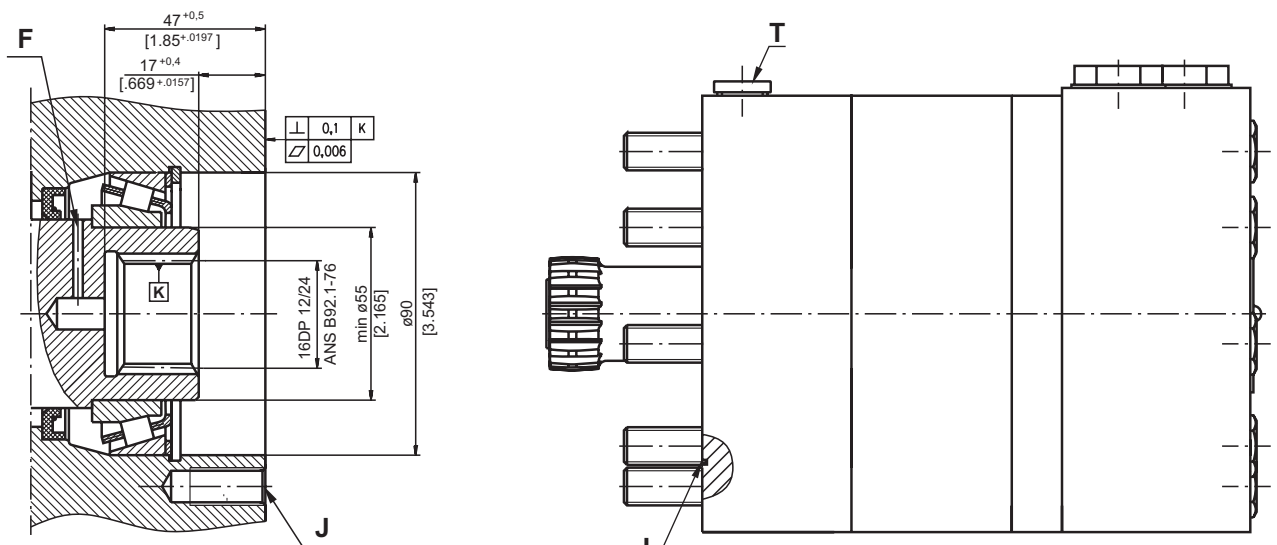

F: Oil circulation hole
J: 9xM12-30 mm [1.181 in] depth, 400, $\phi 110_{\pm 0.1}$ [4.33 \pm 0.039]

I: O- Ring 93x1,5mm [3.661x.059 in]
T: Drain connection G1/4

DIMENSIONS AND MOUNTING DATA - MTM6V

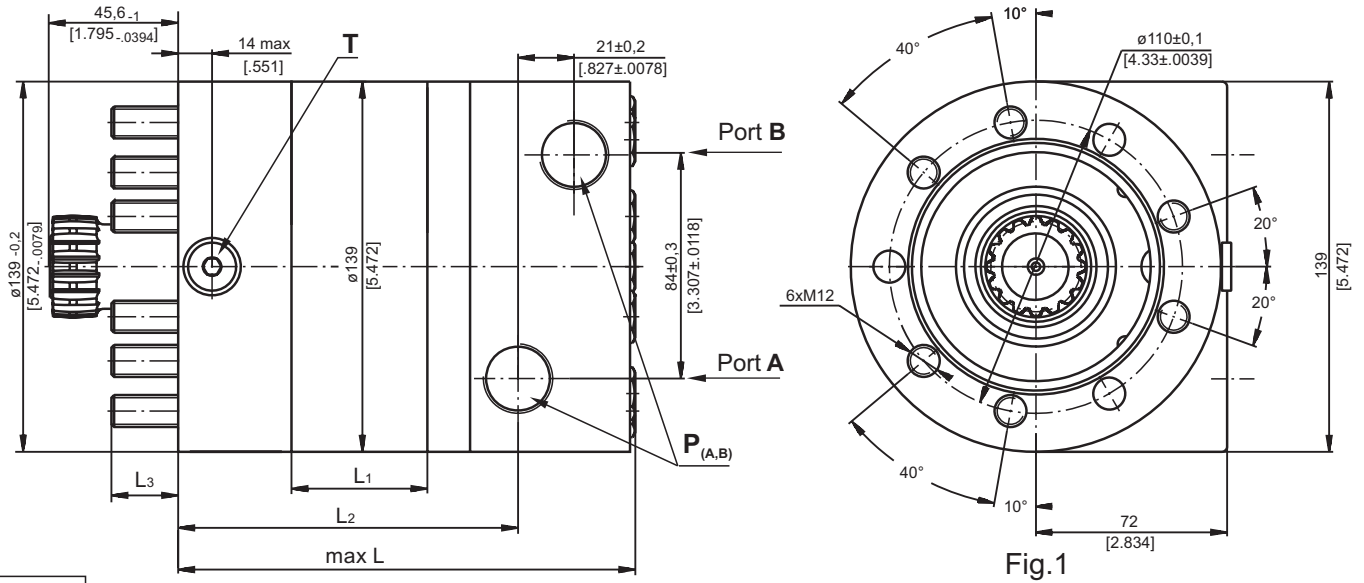

Warning: Drain line should always be used.

P_(A, B) : 2xG3/4 - 17 mm [.669 in] depth
T : G1/4 12 mm [.472 in] depth (plugged)

Standard Rotation
Viewed from Shaft End
Port A Pressurized - CW
Port B Pressurized - CCW

Reverse Rotation
Viewed from Shaft End
Port A Pressurized - CCW
Port B Pressurized - CW

Type	L, mm [in]	L ₁ , mm [in]	L ₂ , mm [in]	L ₃ , mm [in]
MTM6V 200	151 [5.945]	25 [.98]	106,5 [4.193]	27,8 [1.094]
MTM6V 250	157 [6.181]	31,3 [1.23]	112,8 [4.441]	26,5 [1.043]
MTM6V 315	167 [6.575]	40,5 [1.59]	122,0 [4.803]	22,3 [.878]
MTM6V 400	177 [6.968]	51 [2.01]	132,5 [5.217]	21,8 [.858]
MTM6V 470	185 [7.283]	59 [2.32]	140,5 [5.531]	23,8 [.937]
MTM6V 500	191 [7.520]	65 [2.56]	146,5 [5.768]	27,8 [1.094]
MTM6V 630	187 [7.362]	61 [2.40]	142,5 [5.610]	26,8 [1.055]
MTM6V 725	196 [7.717]	70 [2.76]	151,5 [5.965]	27,8 [1.094]

DIMENSIONS OF THE ATTACHED COMPONENT FOR MTM6V

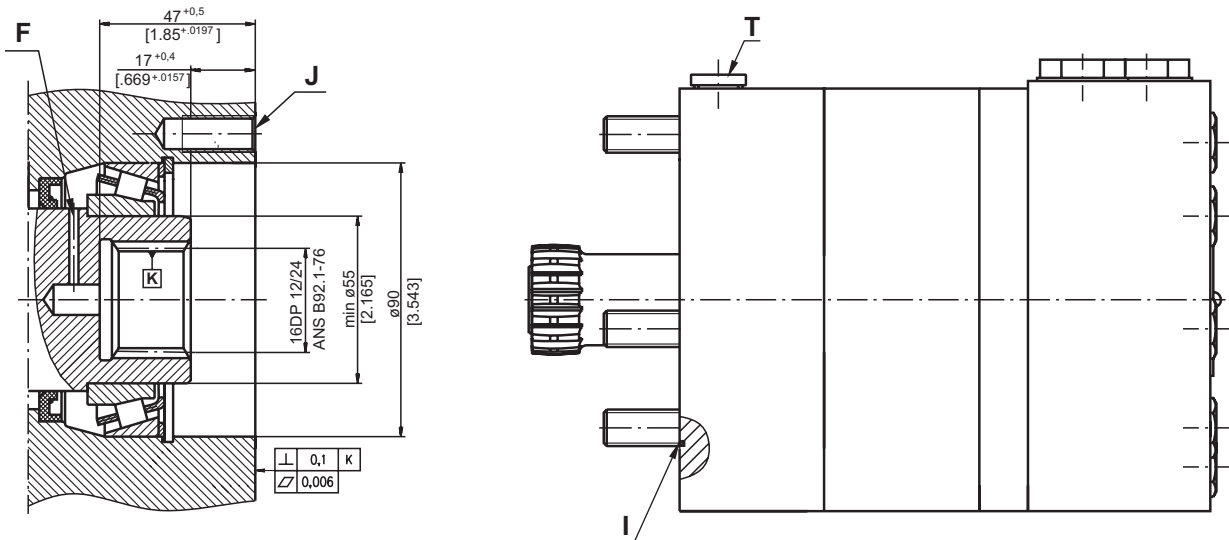

F: Oil circulation hole
J: 9xM12-30 mm [1.181 in] depth, 40°, $\phi 110 \pm 0,1$ [4.33±.0039]
 or 6xM12-30 mm [1.181 in] depth, situated in accordance with the bolts M12, shown on Fig.1, $\phi 110 \pm 0,1$ [4.33±.0039]

I: O- Ring 93x1,5mm [3.661x.059 in]
T: Drain connection G1/4

DRAIN CONNECTION

A drain line ought to be used when pressure in the return line can exceed the permissible pressure. It can be connected at the drain connection of the attached component. The maximum pressure in the drain line is limited by the attached component and its shaft seal.

The drain line must be possible for oil to flow freely between motor and attached component and must be led to the tank. The maximum pressure in the drain line is limited by the attached component and its seal.

INTERNAL SPLINE DATA FOR THE ATTACHED COMPONENT

Standard ANS B92.1-1976, class 5
 [m=2.1166; corrected x.m=+1,0]

Fillet Root Side Fit		inch	mm
Number of Teeth	z	16	16
Diametral Pitch	DP	12/24	12/24
Pressure Angle		30 ⁰	30 ⁰
Pitch Dia.	D	1.3333	33,8656
Major Dia.	D _{ri}	1.5118÷1.5275	38,4 ^{+0,4}
Minor Dia.	D _i	1.2657÷1.2673	32,15 ^{+0,04}
Circular Space Width	L _o	.1763÷.1791	4,516±0,037
Fillet Radius	R	.02	0,5
Dimension Between Two Pins	L	1.063÷1.059	26,9 ^{+0,10}
Pin Dia.	d	.19026÷.19034	4,835±0,001

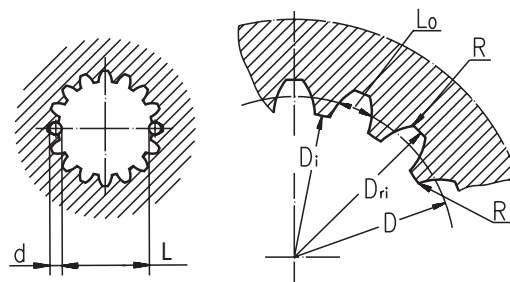

Hardening Specification:
 HV=750±50 on the surface.
 HV=560 at 0,7±0,2 [.035÷.019] case depth
 Material: 20 MoCr4 EN 10084 or SAE8620.

ORDER CODE

	1	2	3	4	5	6	7
MTM							

Pos.1 - Mounting Flange

omit - 4-Bolt flange, spigot dia. ø160, BC ø200

C - 4-Bolt flange, spigot dia. ø125, BC ø160

W - Wheel motor

V - Veryshort mount, 9xM12 mounting bolts

6V - Veryshort mount, 6xM12 mounting bolts

Pos.2 - Displacement code

200 - 201,4 cm³/rev [12.29 in³/rev]

250 - 251,8 cm³/rev [15.36 in³/rev]

315 - 326,3 cm³/rev [19.90 in³/rev]

400 - 410,9 cm³/rev [25.06 in³/rev]

470 - 475,0 cm³/rev [28.97 in³/rev]

500 - 523,6 cm³/rev [31.95 in³/rev]

630 - 631,2 cm³/rev [38.52 in³/rev]

725 - 724,3 cm³/rev [44.20 in³/rev]

Pos.3 - Shaft Extensions*

C - ø40 straight, Parallel key A12x8x70 DIN6885

CO - ø1½" straight, Parallel key 3/8"x3/8"x2¼" BS46

K - ø45 tapered 1:10, Parallel key B12x8x28 DIN6885

SH - ø1½" splined 17T ANSI B92.1-1976

Pos.4 - Check Valves

omit - without check valves

1 - with check valves

Pos.5 - Ports

omit - BSPP (ISO 228)

Pos.6 - Special Features (see page 34)

Pos.7 - Design Series

omit - Factory specified

NOTES:

* The permissible output torque for shafts must be not exceeded!

** Color at customer's request.

The hydraulic motors are mangano-phosphatized as standard.

HYDRAULIC MOTORS TMF



APPLICATION

- » Marine equipment
- » Forestry equipment
- » Metal working machines
- » Agriculture machines
- » Road building machines
- » Mining machinery
- » Special vehicles etc.

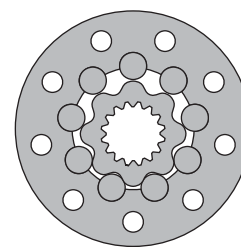
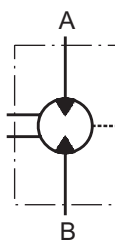

CONTENTS

Specification data	21
Dimensions and mounting TMF.....	22
Dimensions and mounting TMFA	23
Permissible shaft loads	24
Order code	24

OPTIONS

- » Model- Disc valve, roll-gerotor
- » Wheel mounting flange
- » Side ports
- » Shaft- thread hole flange
- » SAE and BSPP ports
- » Other special features

GENERAL

Max. Displacement, cm ³ /rev [in ³ /rev]	724,3 [44.2]
Max. Speed, [RPM]	750
Max. Torque, daNm [in-lb]	cont.: 175 [15490] int.: 215 [16030]
Max. Output, kW [HP]	70 [94]
Max. Pressure Drop, bar [PSI]	cont.: 250 [3600] int.: 350 [5080]
Max. Oil Flow, lpm [GPM]	150 [40]
Min. Speed, [RPM]	5
Permissible Shaft Loads daN [lbs]	P _a =1000 [2250]
Pressure fluid	Mineral based- HLP(DIN 51524) or HM(ISO 6743/4)
Temperature range, °C [°F]	-40÷140 [-40÷284]
Optimal Viscosity range, mm ² /s [SUS]	20÷75 [98÷347]
Filtration	ISO code 20/16 (Min. recommended fluid filtration of 25 micron)

Oil flow in drain line

Pressure drop bar [PSI]	Viscosity mm ² /s [SUS]	Oil flow in drain line lpm [GPM]
200 [2900]	20 [98]	2,5 [.660]
	35 [164]	1,5 [.400]
275 [3990]	20 [98]	4 [1.057]
	35 [164]	2,5 [.660]

Pressure Losses

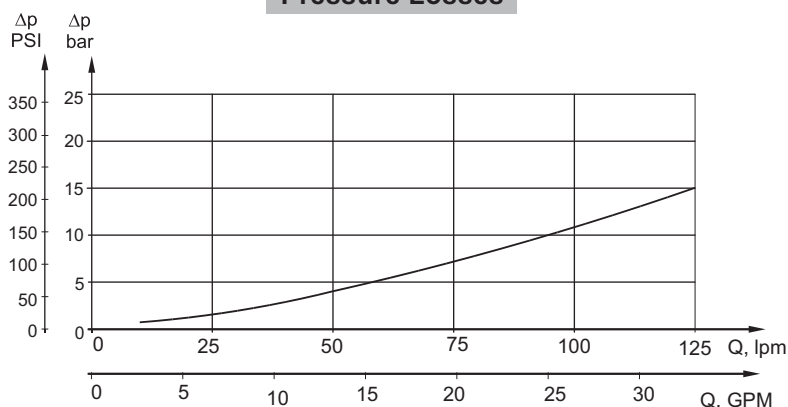

SPECIFICATION DATA

Type		TMF 200	TMF 250	TMF 315	TMF 400	TMF 470	TMF 500	TMF 630	TMF 725
Displacement, cm.³/rev. [in.³/rev.]		201,4 [12.29]	251,8 [15.36]	326,3 [19.9]	410,9 [25.06]	475 [28.97]	523,6 [31.95]	631,2 [38.52]	724 [44.2]
Max. Speed, [RPM]	Cont.	625	500	380	305	260	240	185	170
	Int.*	750	600	460	365	315	285	225	215
Max. Torque daNm [in-lb]	Cont.	72 [6375]	90[7965]	116[10265]	147[13010]	171[15135]	172[15225]	175[15490]	160[14160]
	Int.*	102 [9030]	128[11330]	163[14425]	206[18232]	215[16030]	215[19030]	215[19030]	192[17000]
	Peak**	115[10180]	144[12745]	186[16460]	235[20800]	240[21240]	240[21240]	250[21225]	240[21240]
Max. Output kW [HP]	Cont.	41 [55]	41 [55]	41 [55]	41 [55]	41 [55]	37,5 [50]	28 [37,5]	26 [35]
	Int.*	65 [87]	70 [94]	70 [94]	70 [94]	55 [74]	51 [68]	42 [56]	40 [54]
Max. Pressure Drop bar [PSI]	Cont.	250[3600]	250[3600]	250[3600]	250[3600]	250[3600]	230[3340]	185[2680]	160[2320]
	Int.*	350[5080]	350[5080]	350[5080]	350[5080]	350[5080]	280[4060]	225[3260]	210[3045]
	Peak**	400[5800]	400[5800]	400[5800]	400[5800]	400[5800]	320[4640]	270[3915]	260[3770]
Max. Oil Flow lpm [GPM]	Cont.	125[33]	125[33]	125[33]	125[33]	125[33]	125[33]	125[33]	125[33]
	Int.*	150[40]	150[40]	150[40]	150[40]	150[40]	150[40]	150[40]	150[40]
Max. Inlet Pressure bar [PSI]	Cont.	270[3920]	270[3920]	270[3920]	270[3920]	270[3920]	270[3920]	270[3920]	270[3920]
	Int.*	370[5370]	370[5370]	370[5370]	370[5370]	370[5370]	370[5370]	370[5370]	370[5370]
	Peak**	420[6100]	420[6100]	420[6100]	420[6100]	420[6100]	420[6100]	420[6100]	420[6100]
Max. Return Pressure without Drain Line or Max. Pressure in Drain Line, bar [PSI]	Cont. 0-100 RPM	75 [1100]	75 [1100]	75 [1100]	75 [1100]	75 [1100]	75 [1100]	75 [1100]	75 [1100]
	Cont. 100-300 RPM	40 [580]	40 [580]	40 [580]	40 [580]	40 [580]	40 [580]	40 [580]	40 [580]
	Cont. >300 RPM	20 [290]	20 [290]	20 [290]	20 [290]	20 [290]	-	-	-
	Int.* 0-max. RPM	75 [1100]	75 [1100]	75 [1100]	75 [1100]	75 [1100]	75 [1100]	75 [1100]	75 [1100]
Max. Return Pressure with Drain Line bar [PSI]	Cont.	270[3920]	270[3920]	270[3920]	270[3920]	270[3920]	270[3920]	270[3920]	270[3920]
	Int.*	370[5370]	370[5370]	370[5370]	370[5370]	370[5370]	370[5370]	370[5370]	370[5370]
	Peak**	420[6100]	420[6100]	420[6100]	420[6100]	420[6100]	420[6100]	420[6100]	420[6100]
Max. Starting Pressure with Unloaded Shaft, bar [PSI]		6 [90]	6 [90]	6 [90]	6 [90]	6 [90]	6 [90]	6 [90]	6 [90]
Min. Starting Torque daNm [in-lb]		60[5310]	75[6640]	97[8585]	122[10800]	142[12570]	143[12655]	145[12830]	148[13100]
Min. Speed***, [RPM]		5	5	5	5	5	5	5	5
Weight, kg [lb]		26,9[59.3]	27,3[60.2]	28,1[62]	29 [64]	29,7[65.5]	30,2[66.6]	29,7[65.5]	31[68.4]

* Intermittent operation: the permissible values may occur for max. 10% of every minute.

** Peak load: the permissible values may occur for max. 1% of every minute.

*** For speeds of 5 RPM lower than given, consult factory or your regional manager.

1. Intermittent speed and intermittent pressure must not occur simultaneously.
2. Recommended filtration is per ISO cleanliness code 20/16. A nominal filtration of 25 micron or better.
3. Recommend using a premium quality, anti-wear type mineral based hydraulic oil, HLP(DIN51524) or HM(ISO6743/4). If using synthetic fluids consult the factory for alternative seal materials.
4. Recommended minimum oil viscosity 70 SUS [13 cm²/s] at 50°C [122°F].
5. Recommended maximum system operating temperature is 82°C [180°F].
6. To assure optimum motor life fill with fluid prior to loading and run at moderate load and speed for 10-15 minutes.

DIMENSIONS AND MOUNTING DATA - TMF

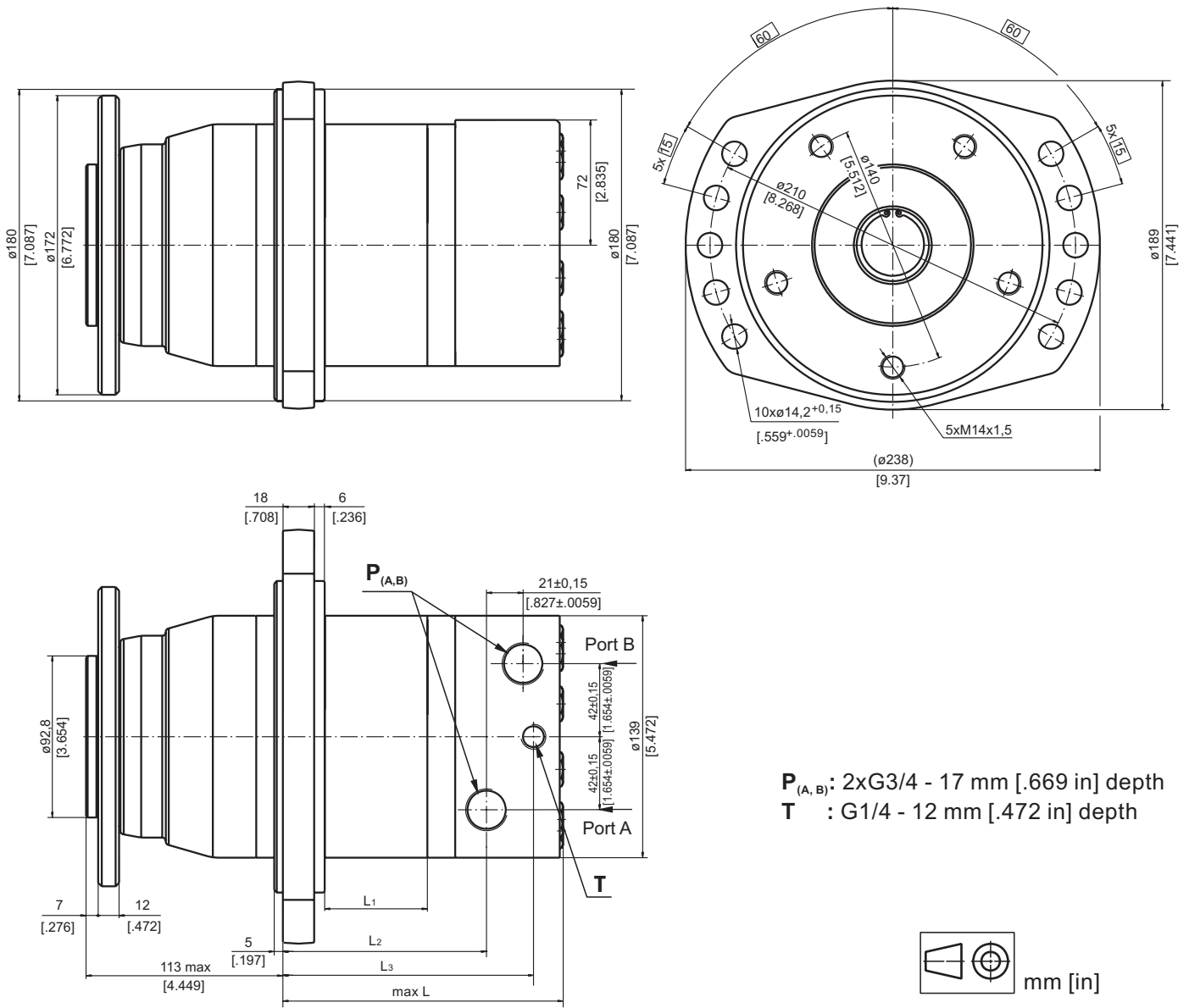

Warning: Drain line should always be used.

Standard Rotation
 Viewed from Shaft End
 Port **A** Pressurized - **CW**
 Port **B** Pressurized - **CCW**

Reverse Rotation
 Viewed from Shaft End
 Port **A** Pressurized - **CCW**
 Port **B** Pressurized - **CW**

Type	L, mm [in]	L ₁ , mm [in]	L ₂ , mm [in]	L ₃ , mm [in]
TMF 200	126 [4.96]	.98 [25]	83 [3.268]	110,3 [4.34]
TMF 250	132.3 [5.21]	31,3 [1.23]	89.3 [3.516]	116,6 [4.59]
TMF 315	141.5 [5.57]	40,5 [1.59]	98.5 [3.878]	125,8 [4.95]
TMF 400	152 [5.98]	51 [2.01]	109 [4.291]	136,3 [5.37]
TMF 470	160 [6.30]	59 [2.32]	117 [4.606]	144,3 [5.68]
TMF 500	166 [6.54]	65 [2.56]	123 [4.843]	150,3 [5.92]
TMF 630	162 [6.38]	61 [2.40]	119 [4.69]	146,3 [5.76]
TMF 725	171 [6.73]	70 [2.76]	128 [5.04]	155,3 [6.11]

DIMENSIONS AND MOUNTING DATA - TMFA

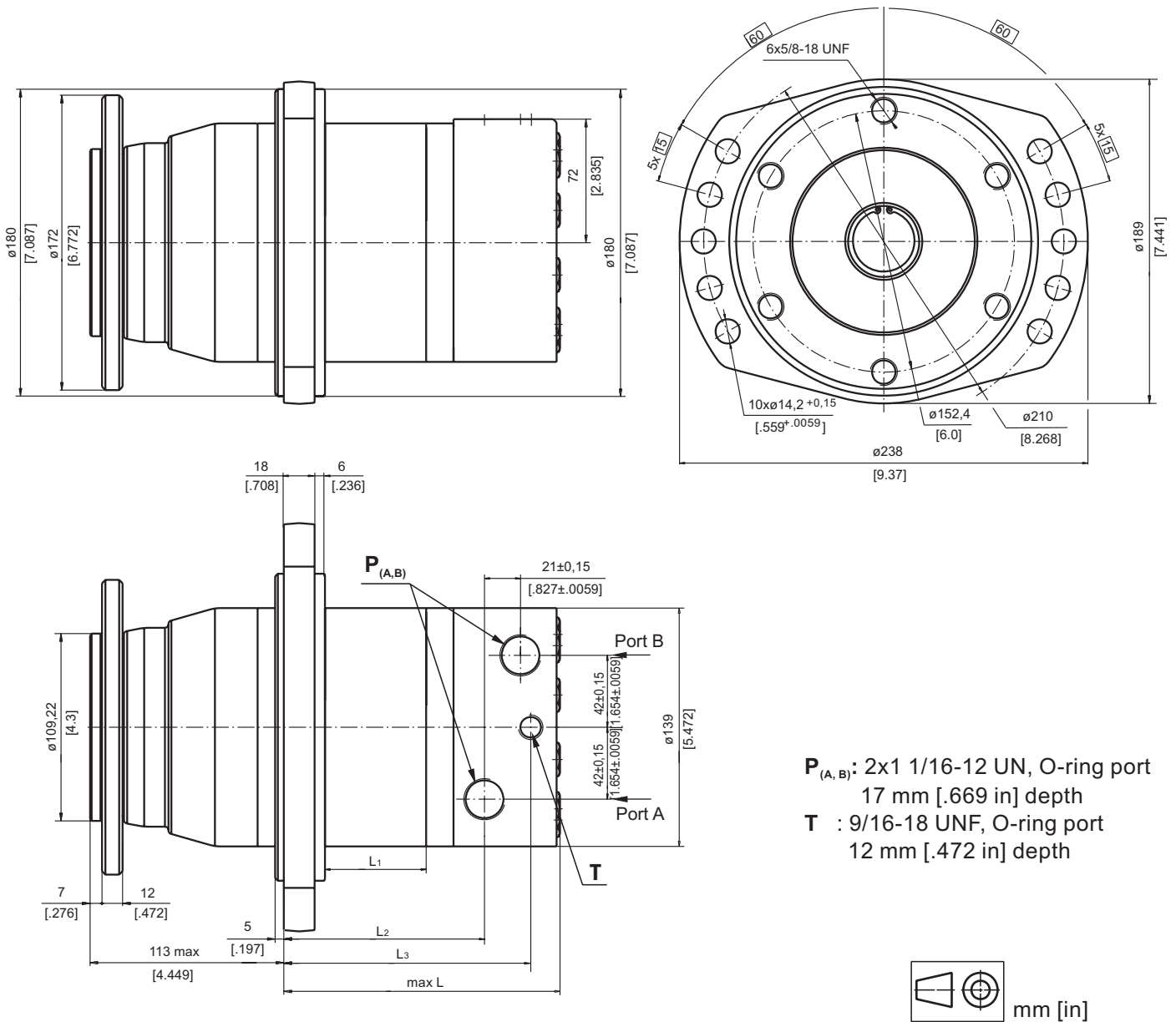

Warning: Drain line should always be used.

Standard Rotation
 Viewed from Shaft End
 Port A Pressurized - **CW**
 Port B Pressurized - **CCW**

Reverse Rotation
 Viewed from Shaft End
 Port A Pressurized - **CCW**
 Port B Pressurized - **CW**

Type	L, mm [in]	L1, mm [in]	L2, mm [in]	L3, mm [in]
TMFA 200	126 [4.96]	.98 [25]	83 [3.268]	110,3 [4.34]
TMFA 250	132.3 [5.21]	31,3 [1.23]	89.3 [3.516]	116,6 [4.59]
TMFA 315	141.5 [5.57]	40,5 [1.59]	98.5 [3.878]	125,8 [4.95]
TMFA 400	152 [5.98]	51 [2.01]	109 [4.291]	136,3 [5.37]
TMFA 470	160 [6.30]	59 [2.32]	117 [4.606]	144,3 [5.68]
TMFA 500	166 [6.54]	65 [2.56]	123 [4.843]	150,3 [5.92]
TMFA 630	162 [6.38]	61 [2.40]	119 [4.69]	146,3 [5.76]
TMFA 725	171 [6.73]	70 [2.76]	128 [5.04]	155,3 [6.11]

PERMISSIBLE SHAFT LOADS

The load diagram is valid for an average bearings life of 2000 hours at 100 RPM

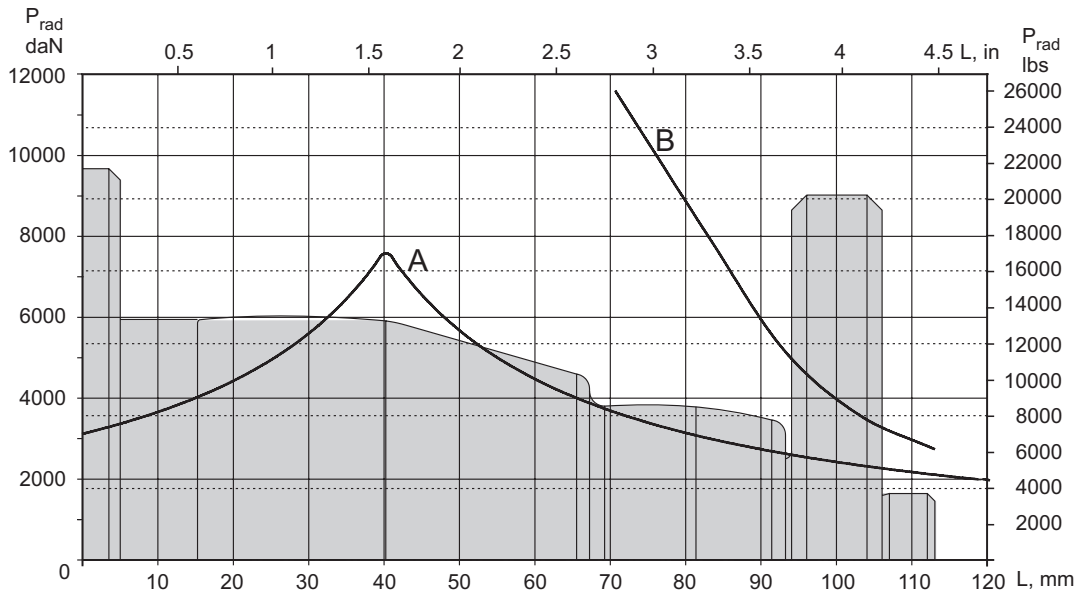

- A** - Permissible radial shaft load.
- B** - Max. radial shaft load. Any shaft load exceeding the values shown in the curve will involve a risk of breakage

ORDER CODE

	1	2	3	4
TMF				

- Pos.1 - Mounting Flange**
- omit - Thread hole flange, 5xM12x1,5 on \varnothing 140
 - A** - Thread hole flange, 6x5/8-18 UNF on \varnothing 152,4

- Pos.2 - Displacement code**
- | | |
|------------|---|
| 200 | - 201,4 [12.29] cm. ³ /rev. [in. ³ /rev.] |
| 250 | - 251,8 [15.36] cm. ³ /rev. [in. ³ /rev.] |
| 315 | - 326,3 [19.90] cm. ³ /rev. [in. ³ /rev.] |
| 400 | - 410,9 [25.06] cm. ³ /rev. [in. ³ /rev.] |
| 470 | - 475,0 [28.97] cm. ³ /rev. [in. ³ /rev.] |
| 500 | - 523,6 [31.95] cm. ³ /rev. [in. ³ /rev.] |
| 630 | - 631,2 [38.52] cm. ³ /rev. [in. ³ /rev.] |
| 725 | - 724,3 [44.20] cm. ³ /rev. [in. ³ /rev.] |

- Pos.3 - Special Features** (see page 34)

- Pos.4 - Design Series**
- omit - Factory specified

The hydraulic motors are manganophosphatized as standard.

HYDRAULIC MOTORS MVM

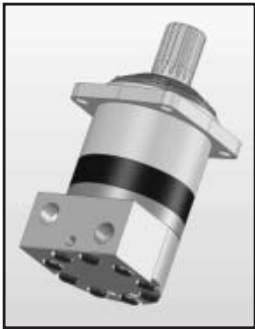

APPLICATION

- » Conveyors
- » Metal working machines
- » Agriculture machines
- » Road building machines
- » Mining machinery
- » Food industries
- » Special vehicles
- » Plastic and rubber machinery etc.

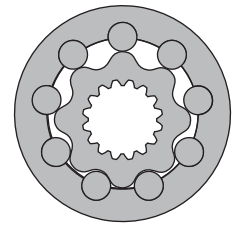
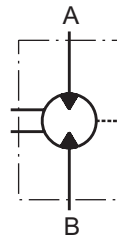

CONTENTS

Specification data	26
Dimensions and mounting	27
Shaft extensions	27
Permissible shaft Seal Pressure	28
Permissible shaft loads	29
Order code	29

OPTIONS

- » Model- Disc valve, roll-gerotor
- » Flange with wheel mount
- » Short motor
- » Side ports
- » Shafts- straight, splined and tapered
- » BSPP ports;
- » Other special features.

EXCELLENCE

- » High torque and pressure drop
- » High inlet pressure
- » High starting torque
- » Improved efficiency at high pressure drop
- » Smooth operation at low speed
- » High radial and axial bearing capacity

GENERAL

Max. Displacement, cm ³ /rev [in ³ /rev]	801,8 [48.91]
Max. Speed, [RPM]	736
Max. Torque, daNm [lb-in]	cont.: 259 [22920] int.: 340 [30090]
Max. Output, kW [HP]	112 [150]
Max. Pressure Drop, bar [PSI]	cont.: 250 [3630] int.: 350 [5080]
Max. Oil Flow, lpm [GPM]	240 [63.4]
Min. Speed, [RPM]	5
Permissible Shaft Loads, daN [lbs]	Pa=1500 [3370]
Pressure fluid	Mineral based- HLP(DIN 51524) or HM(ISO 6743/4)
Temperature range, °C [°F]	-40÷140 [-40÷284]
Optimal Viscosity range, mm ² /s [SUS]	20÷75 [98÷347]
Filtration	ISO code 20/16 (Min. recommended fluid filtration of 25 micron)

Oil flow in drain line

Pressure drop bar [PSI]	Viscosity mm ² /s [SUS]	Oil flow in drain line lpm [GPM]
200 [2900]	20 [98]	2,5 [.660]
	35 [164]	1,5 [.400]
275 [3990]	20 [98]	4 [1.057]
	35 [164]	2,5 [.660]

Pressure Losses

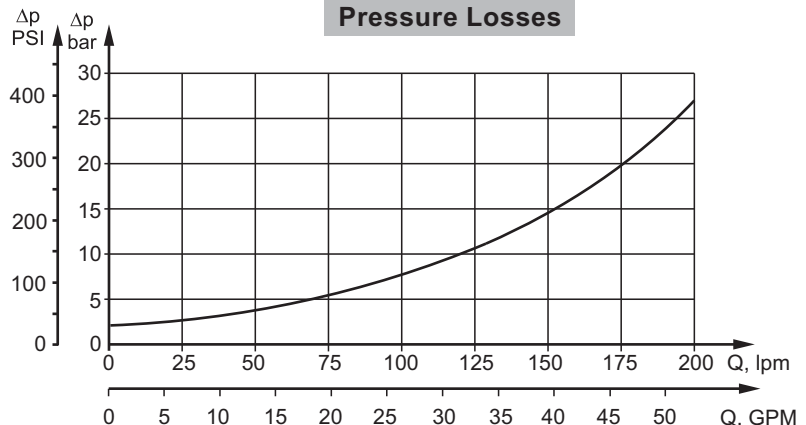

SPECIFICATION DATA

Type	MVM 315	MVM 400	MVM 500	MVM 630	MVM 800	
Displacement, cm³/rev. [in³/rev.]	314,5 [19.18]	400,9 [24.5]	499,6 [30.5]	629,1 [38.38]	801,8 [48.91]	
Max. Speed, [RPM]	cont.	636	500	400	315	250
	Int.*	736	600	480	380	300
Max. Torque daNm [lb-in]	cont.	115 [10180]	144 [12745]	180 [15930]	227 [20090]	259 [22920]
	Int.*	160 [14160]	200 [17700]	260 [23010]	310 [27440]	340 [30090]
	peak**	180 [15930]	230 [20355]	286 [25315]	360 [31860]	402 [35580]
Max. Output kW [HP]	cont.	67 [90]	67 [90]	67 [90]	67 [90]	67 [90]
	int.*	112 [150]	112 [150]	112 [150]	112 [150]	112 [150]
Max. Pressure Drop bar [PSI]	cont.	250 [3630]	250 [3630]	250 [3630]	250 [3630]	225 [3263]
	Int.*	350 [5080]	350 [5080]	350 [5080]	350 [5080]	300 [4350]
	peak**	400 [5800]	400 [5800]	400 [5800]	400 [5800]	350 [5080]
Max. Oil Flow lpm [GPM]	cont.	200 [52.8]	200 [52.8]	200 [52.8]	200 [52.8]	200 [52.8]
	Int.*	240 [63.4]	240 [63.4]	240 [63.4]	240 [63.4]	240 [63.4]
Max. Inlet Pressure bar [PSI]	cont.	270 [3915]	270 [3915]	270 [3915]	270 [3915]	270 [3915]
	Int.*	370 [5365]	370 [5365]	370 [5365]	370 [5365]	370 [5365]
	peak**	420 [6090]	420 [6090]	420 [6090]	420 [6090]	420 [6090]
Max. Return Pressure with Drain Line bar [PSI]	cont.	140 [2030]	140 [2030]	140 [2030]	140 [2030]	140 [2030]
	Int.*	175 [2540]	175 [2540]	175 [2540]	175 [2540]	175 [2540]
	peak**	210 [3045]	210 [3045]	210 [3045]	210 [3045]	210 [3045]
Max. Starting Pressure with Unloaded Shaft, bar [PSI]	5 [70]	5 [70]	5 [70]	5 [70]	5 [70]	
Min. Starting Torque daNm [lb-in]	92 [8140]	115 [10180]	144 [12745]	180 [15930]	205 [18145]	
Min. Speed***, [RPM]	10	6	8	6	5	
Weight, kg [lb]	41,3 [91]	42,1 [93]	43 [95]	44,5 [98]	46 [101.4]	

* Intermittent operation: the permissible values may occur for max. 10% of every minute.

** Peak load: the permissible values may occur for max. 1% of every minute.

*** For speeds lower than given, consult factory or your regional manager.

1. Intermittent speed and intermittent pressure must not occur simultaneously.
2. Recommended filtration is per ISO cleanliness code 20/16. A nominal filtration of 25 micron or better.
3. Recommend using a premium quality, anti-wear type mineral based hydraulic oil HLP(DIN51524) or HM (ISO 6743/4).
If using synthetic fluids consult the factory for alternative seal materials.
4. Recommended minimum oil viscosity 13 mm²/s [70 SUS] at 50°C [122°F].
5. Recommended maximum system operating temperature is 82°C [180°F].
6. To assure optimum motor life fill with fluid prior to loading and run at moderate load and speed for 10-15 minutes.

DIMENSIONS AND MOUNTING DATA

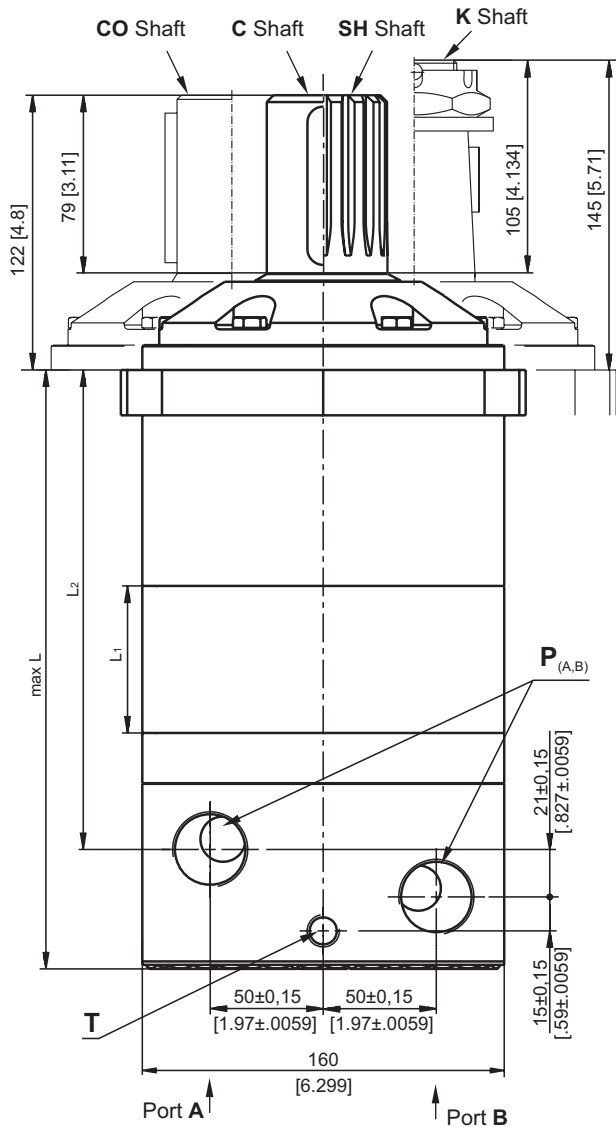

Shaft Dim.
See Page 28

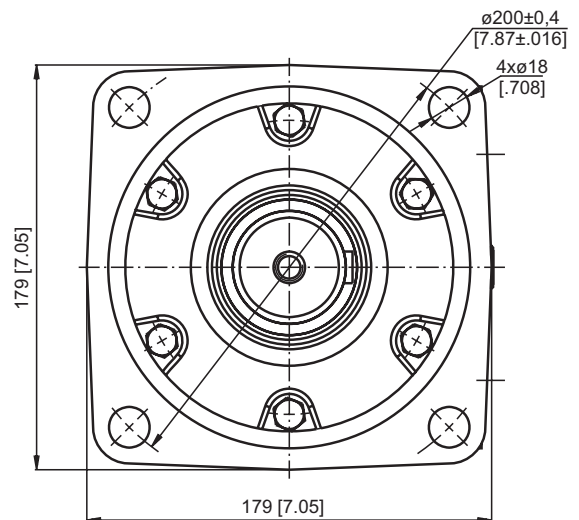
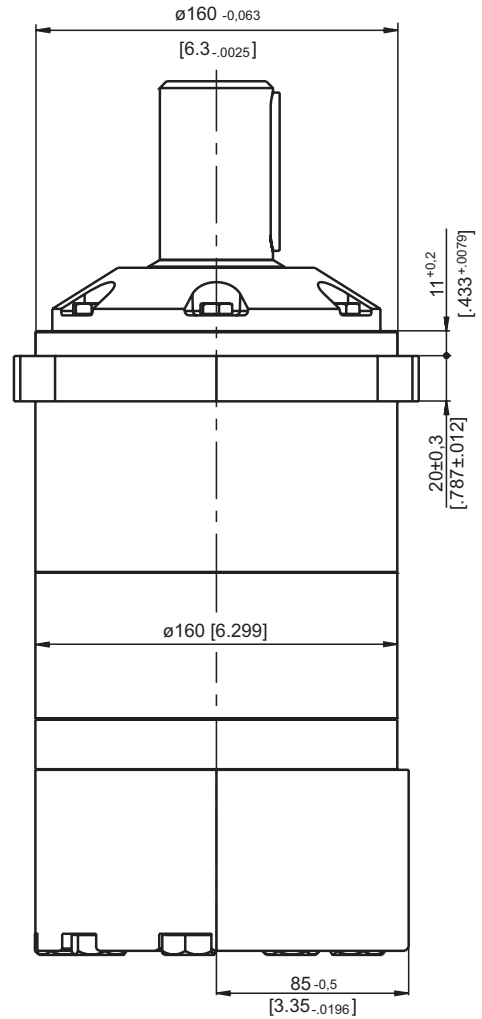

	Versions	
	2	4
P (A,B)	2xG1	2x1 ⁵ / ₁₆ -12UN
T	G ¹ / ₄	9 ¹⁶ -18UNF

Warning: Drain line should always be used.

Type	L, mm [in]	L ₂ , mm [in]	L ₁ , mm [in]
MVM 315	226,5 [8.92]	172,5 [6.79]	25,5 [1.00]
MVM 400	233,5 [9.19]	179,5 [7.07]	32,5 [1.28]
MVM 500	241,5 [9.51]	187,5 [7.38]	40,5 [1.59]
MVM 630	252 [9.92]	198 [7.79]	51 [2.01]
MVM 800	266 [10.47]	212 [8.35]	65 [2.56]

Standard Rotation
Viewed from Shaft End
Port A Pressurized - **CW**
Port B Pressurized - **CCW**

Reverse Rotation
Viewed from Shaft End
Port A Pressurized - **CCW**
Port B Pressurized - **CW**



SHAFT EXTENSIONS

C - $\varnothing 50$ straight, Parallel key A14x9x70 DIN 6885

CO - $\varnothing 2\frac{1}{4}$ " [57,15] straight, Parallel key $\frac{1}{2}$ " x $\frac{1}{2}$ " x $2\frac{1}{4}$ " BS46

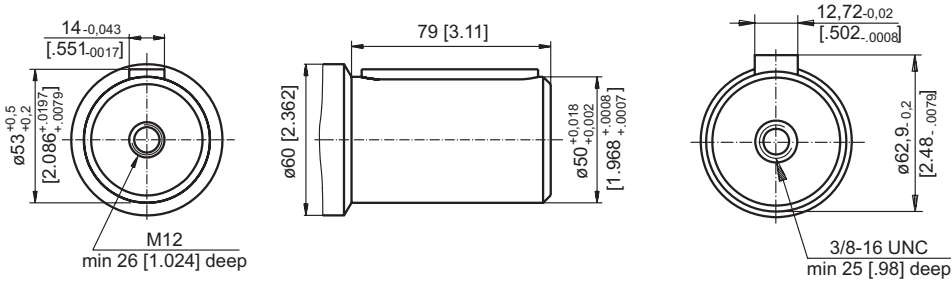

SH - $\varnothing 2\frac{1}{8}$ " splined, 16 DP 8/16 ANS B92.1-1976

K - tapered 1:10, Parallel key B16x10x32 DIN 6885

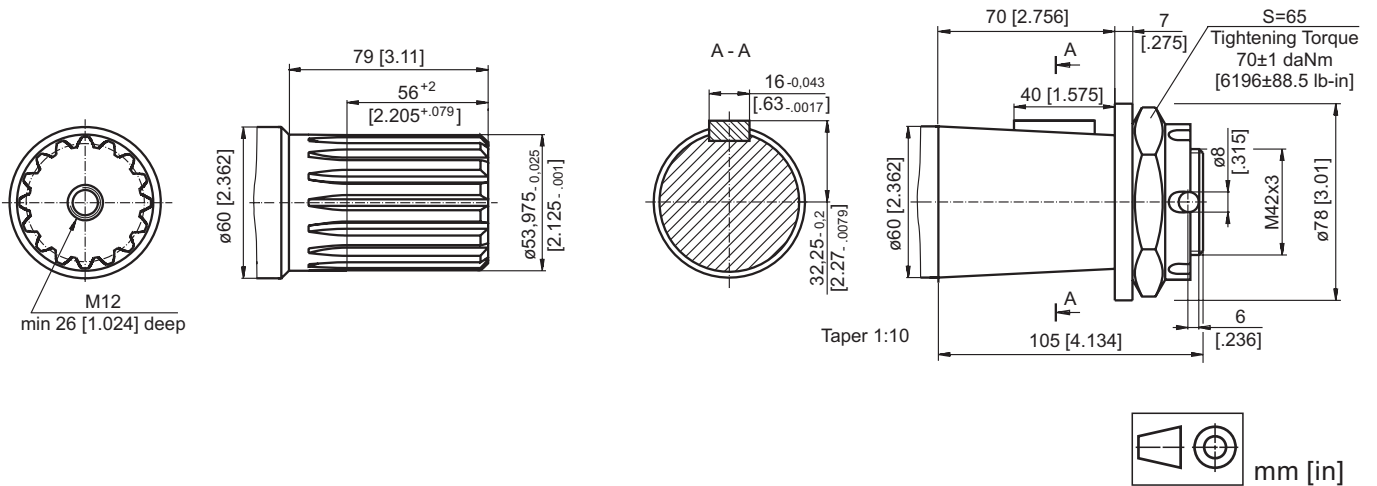

MAX. PERMISSIBLE SHAFT SEAL PRESSURE

**Max. return pressure without drain line or
max. pressure in the drain line**

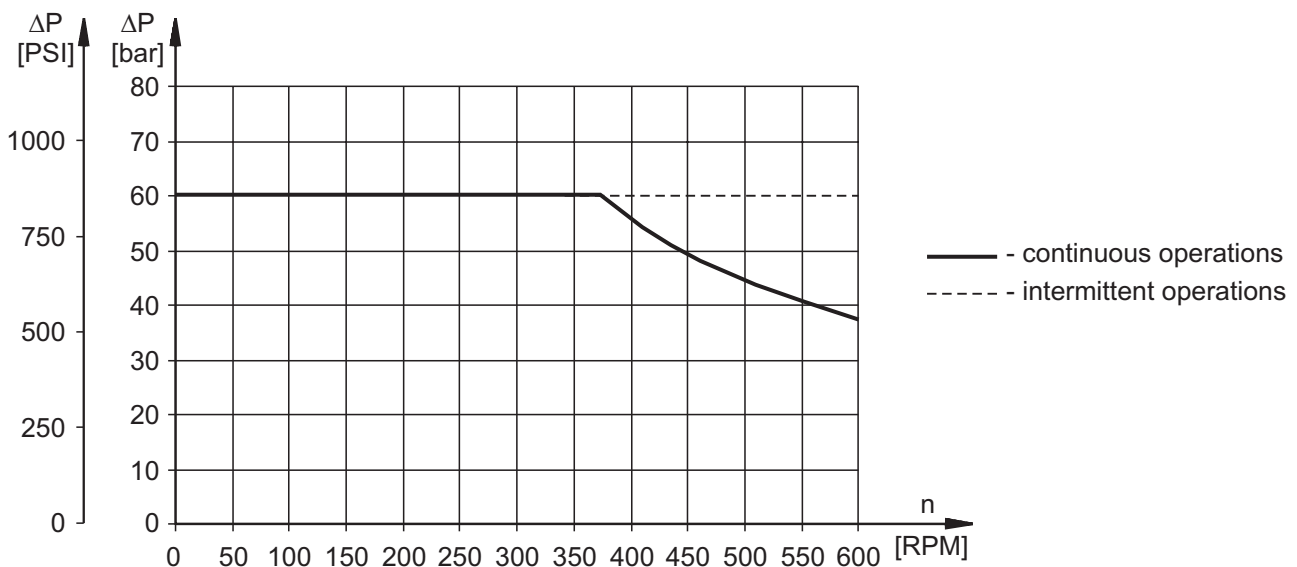

PERMISSIBLE SHAFT LOADS

The output shaft runs in tapered bearings that permit high axial and radial forces. Curve "1" shows max. radial shaft load. Any shaft load exceeding the values quoted in the curve will seriously reduce motor life. The two other curves apply to a B10 bearing life of 3000 hours at 200 RPM.

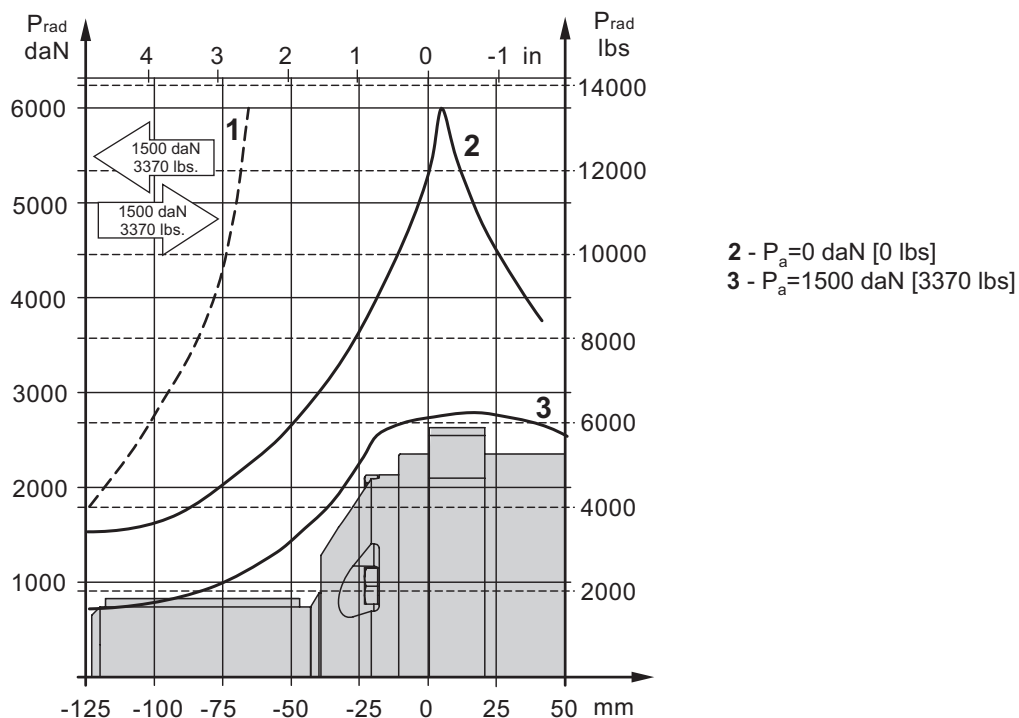

ORDER CODE

	1	2	3	4	5	6
M V M						

Pos.1 - Displacement code

315	- 314,5 cm ³ /rev [19.8 in ³ /rev]
400	- 400,9 cm ³ /rev [24.45 in ³ /rev]
500	- 499,6 cm ³ /rev [30.48 in ³ /rev]
630	- 629,1 cm ³ /rev [38.38 in ³ /rev]
800	- 801,8 cm ³ /rev [48.91 in ³ /rev]

Pos.2 - Shaft Extensions*

C	- ø50 straight, Parallel key A14x9x70 DIN6885
CO	- ø2 ¹ / ₄ " straight, Parallel key 1 ¹ / ₂ "x1 ¹ / ₂ "x2 ¹ / ₄ " DIN6885
SH	- ø2 ¹ / ₈ " splined, ANS B92.1-1976
K	- ø60 tapered 1:10, Parallel key B16x10x32 DIN6885

Pos.3 - Ports

2	- side ports, 2xG1, G1/4, BSP thread, ISO 228
4	- side ports, 2x1 5/16-12 UN, O-ring, 9/16-18 UNF

Pos.4 - Check Valves

	- omit - without check valves
1	- with check valves

Pos.5 - Special Features (see page 34)

Pos.6 - Design Series

	- omit - Factory specified
--	----------------------------

NOTES:

* The permissible output torque for shafts must be not exceeded!

The hydraulic motors are mangano-phosphatized as standard.

HYDRAULIC MOTORS VMF



APPLICATION

- » Marine equipment
- » Forestry equipment
- » Metal working machines
- » Agriculture machines
- » Road building machines
- » Mining machinery
- » Special vehicles etc.

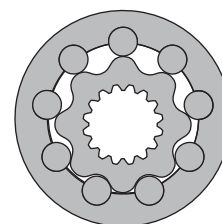

CONTENTS

Specification data	31
Dimensions and mounting	32
Permissible shaft seal pressure.....	32
Permissible shaft loads	33
Order code	33

OPTIONS

- » Model- Disc valve, roll-gerotor
- » Wheel mounting flange
- » Side ports
- » Shaft- thread hole flange
- » SAE and BSPP ports
- » Other special features

GENERAL

Max. Displacement, cm ³ /rev [in ³ /rev]	801,8 [48.91]
Max. Speed, [RPM]	736
Max. Torque, daNm [lb-in]	cont.: 259 [22920] int.: 340 [30090]
Max. Output, kW [HP]	112 [150]
Max. Pressure Drop, bar [PSI]	cont.: 250 [3630] int.: 350 [5080]
Max. Oil Flow, lpm [GPM]	240 [63.4]
Min. Speed, [RPM]	5
Permissible Shaft Loads, daN [lbs]	Pa=1500 [3370]
Pressure fluid	Mineral based- HLP(DIN 51524) or HM(ISO 6743/4)
Temperature range, °C [°F]	-40÷140 [-40÷284]
Optimal Viscosity range, mm ² /s [SUS]	20÷75 [98÷347]
Filtration	ISO code 20/16 (Min. recommended fluid filtration of 25 micron)

Oil flow in drain line

Pressure drop bar [PSI]	Viscosity mm ² /s [SUS]	Oil flow in drain line lpm [GPM]
200 [2900]	20 [98]	2,5 [.660]
	35 [164]	1,5 [.400]
275 [3990]	20 [98]	4 [1.057]
	35 [164]	2,5 [.660]

Pressure Losses

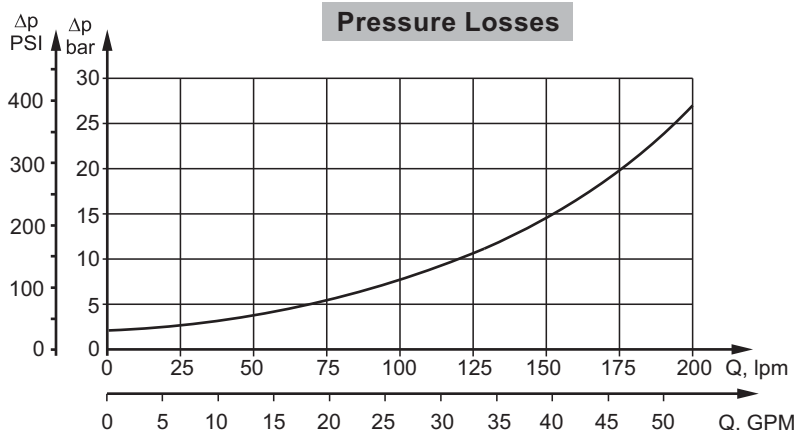

SPECIFICATION DATA

Type	VMF 315	VMF 400	VMF 500	VMF 630	VMF 800	
Displacement, cm³/rev. [in³/rev.]	314,5 [19.18]	400,9 [24.5]	499,6 [30.5]	629,1 [38.38]	801,8 [48.91]	
Max. Speed, [RPM]	cont.	636	500	400	315	250
	Int.*	736	600	480	380	300
Max. Torque daNm [lb-in]	cont.	115 [10180]	144 [12745]	180 [15930]	227 [20090]	259 [22920]
	Int.*	160 [14160]	200 [17700]	260 [23010]	310 [27440]	340 [30090]
	peak**	180 [15930]	230 [20355]	286 [25315]	360 [31860]	402 [35580]
Max. Output kW [HP]	cont.	67 [90]	67 [90]	67 [90]	67 [90]	67 [90]
	int.*	112 [150]	112 [150]	112 [150]	112 [150]	112 [150]
Max. Pressure Drop bar [PSI]	cont.	250 [3630]	250 [3630]	250 [3630]	250 [3630]	225 [3263]
	Int.*	350 [5080]	350 [5080]	350 [5080]	350 [5080]	300 [4350]
	peak**	400 [5800]	400 [5800]	400 [5800]	400 [5800]	350 [5080]
Max. Oil Flow lpm [GPM]	cont.	200 [52.8]	200 [52.8]	200 [52.8]	200 [52.8]	200 [52.8]
	Int.*	240 [63.4]	240 [63.4]	240 [63.4]	240 [63.4]	240 [63.4]
Max. Inlet Pressure bar [PSI]	cont.	270 [3915]	270 [3915]	270 [3915]	270 [3915]	270 [3915]
	Int.*	370 [5365]	370 [5365]	370 [5365]	370 [5365]	370 [5365]
	peak**	420 [6090]	420 [6090]	420 [6090]	420 [6090]	420 [6090]
Max. Return Pressure with Drain Line bar [PSI]	cont.	140 [2030]	140 [2030]	140 [2030]	140 [2030]	140 [2030]
	Int.*	175 [2540]	175 [2540]	175 [2540]	175 [2540]	175 [2540]
	peak**	210 [3045]	210 [3045]	210 [3045]	210 [3045]	210 [3045]
Max. Starting Pressure with Unloaded Shaft, bar [PSI]	5 [70]	5 [70]	5 [70]	5 [70]	5 [70]	
Min. Starting Torque daNm [lb-in]	92 [8140]	115 [10180]	144 [12745]	180 [15930]	205 [18145]	
Min. Speed***, [RPM]	10	6	8	6	5	
Weight, kg [lb]	46 [101.4]	47,2 [104,1]	48,5 [106.9]	50 [110.2]	51,5 [113.5]	

* Intermittent operation: the permissible values may occur for max. 10% of every minute.

** Peak load: the permissible values may occur for max. 1% of every minute.

*** For speeds lower than given, consult factory or your regional manager.

1. Intermittent speed and intermittent pressure must not occur simultaneously.
2. Recommended filtration is per ISO cleanliness code 20/16. A nominal filtration of 25 micron or better.
3. Recommend using a premium quality, anti-wear type mineral based hydraulic oil HLP(DIN51524) or HM (ISO 6743/4).
If using synthetic fluids consult the factory for alternative seal materials.
4. Recommended minimum oil viscosity 13 mm²/s [70 SUS] at 50°C [122°F].
5. Recommended maximum system operating temperature is 82°C [180°F].
6. To assure optimum motor life fill with fluid prior to loading and run at moderate load and speed for 10-15 minutes.

DIMENSIONS AND MOUNTING DATA

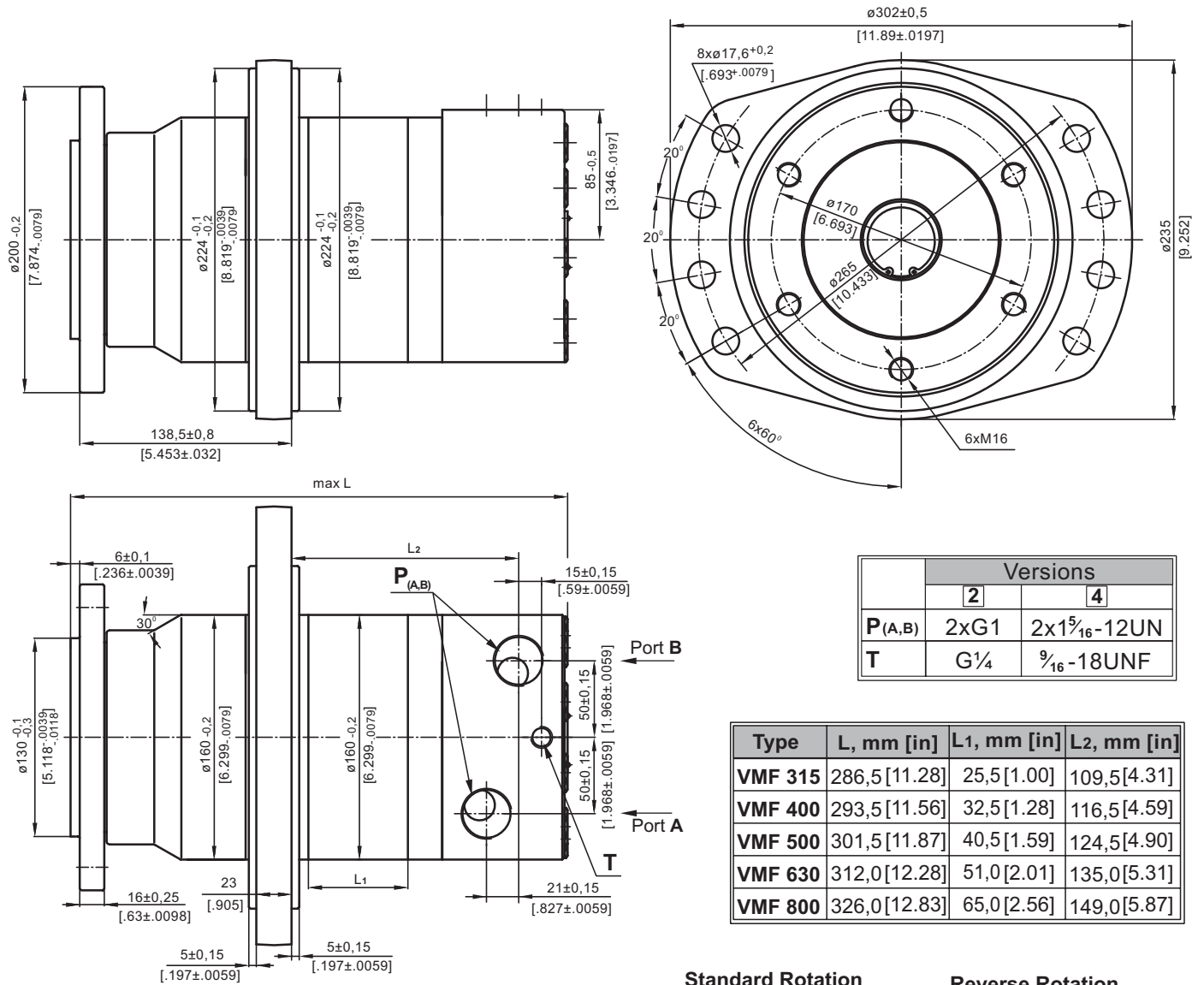

	Versions	
	2	4
P(A,B)	2xG1	2x1 ⁵ / ₁₆ -12UN
T	G ¹ / ₄	9 ¹⁶ / ₁₆ -18UNF

Type	L, mm [in]	L1, mm [in]	L2, mm [in]
VMF 315	286,5 [11.28]	25,5 [1.00]	109,5 [4.31]
VMF 400	293,5 [11.56]	32,5 [1.28]	116,5 [4.59]
VMF 500	301,5 [11.87]	40,5 [1.59]	124,5 [4.90]
VMF 630	312,0 [12.28]	51,0 [2.01]	135,0 [5.31]
VMF 800	326,0 [12.83]	65,0 [2.56]	149,0 [5.87]

Standard Rotation
Viewed from Shaft End
Port A Pressurized - **CW**
Port B Pressurized - **CCW**

Reverse Rotation
Viewed from Shaft End
Port A Pressurized - **CCW**
Port B Pressurized - **CW**

Warning: Drain line should always be used.

MAX. PERMISSIBLE SHAFT SEAL PRESSURE

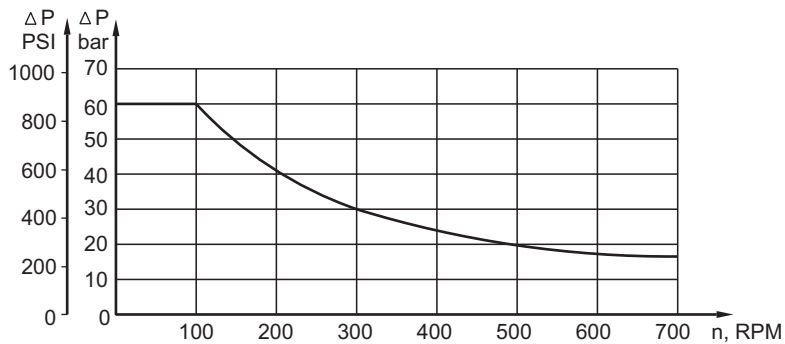

PERMISSIBLE SHAFT LOADS

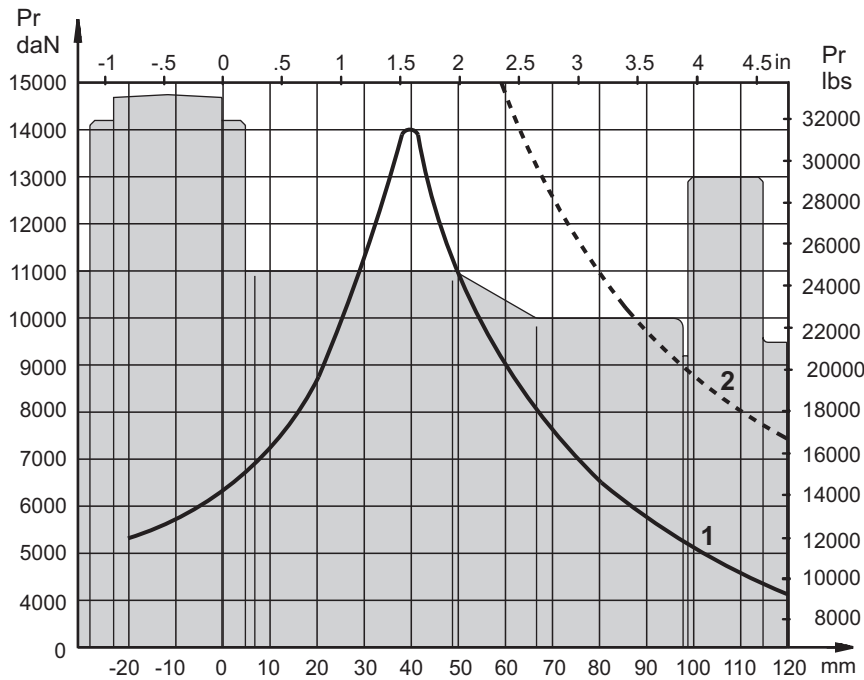

- 1 - Bearing curve: The curve applies to a B10 bearing life of 2000 hours at 100 RPM.
- 2 - Shaft curve: The curve represents Max. permissible radial shaft load with safety factor 2:1.

ORDER CODE

	1	2	3	4
VMF				

Pos.1 - Displacement code

315	- 314,5 cm ³ /rev [19.18 in ³ /rev]
400	- 400,9 cm ³ /rev [24.45 in ³ /rev]
500	- 499,6 cm ³ /rev [30.48 in ³ /rev]
630	- 629,1 cm ³ /rev [38.38 in ³ /rev]
800	- 801,8 cm ³ /rev [48.91 in ³ /rev]

Pos.2 - Ports

2	- side ports, 2xG1, G ¹ / ₄ , BSP thread, ISO 228
4	- side ports, 2x1 ⁵ / ₁₆ -12 UN, O-ring, ¹ / ₁₆ -18 UNF

Pos.3 - Special Features (see page 34)

Pos.4 - Design Series

omit - Factory specified

The hydraulic motors are mangano-phosphatized as standard.

MOTOR SPECIAL FEATURES

Special Feature Description	Order Code	Motor type				
		MSWM	MTM	TMF	MVM	VMF
Speed Sensor*	RS	O	O	O	O	O
Reinforced motor	HD	-	O	O	O	O
Low Leakage	LL	O	O	O	O	O
Low Speed Valving	LSV	O	O	O	O	O
Reverse Rotation	R	O	O	O	O	O
Paint**	P	O	O	O	O	O
Corrosion Protected Paint**	PC	O	O	O	O	O
Check Valves		S	O	-	O	-

- O** Optional
- Not applicable
- S** Standard

* For sensor ordering see pages 35-36.

** Color at customer's request.

 For more information about **HD** option please contact with "M+S Hydraulic".

MOTORS WITH SPEED SENSOR

MSWM...RS

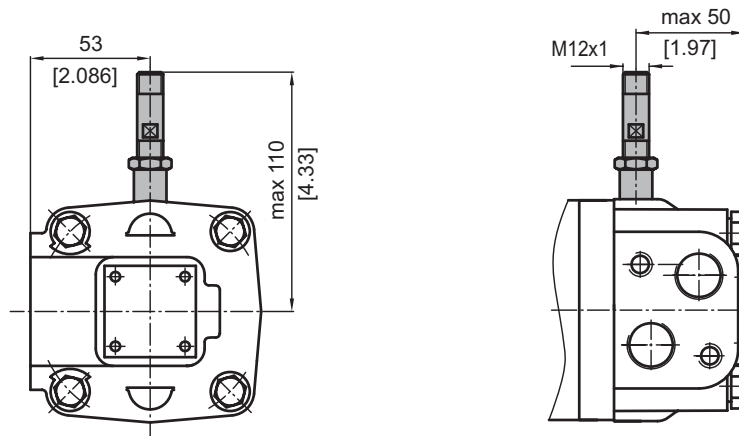

MTM...RS TMF...RS

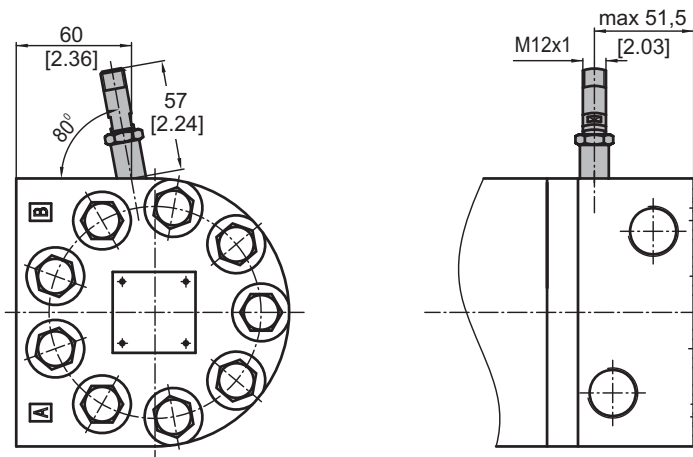

MVM...RS VMF...RS

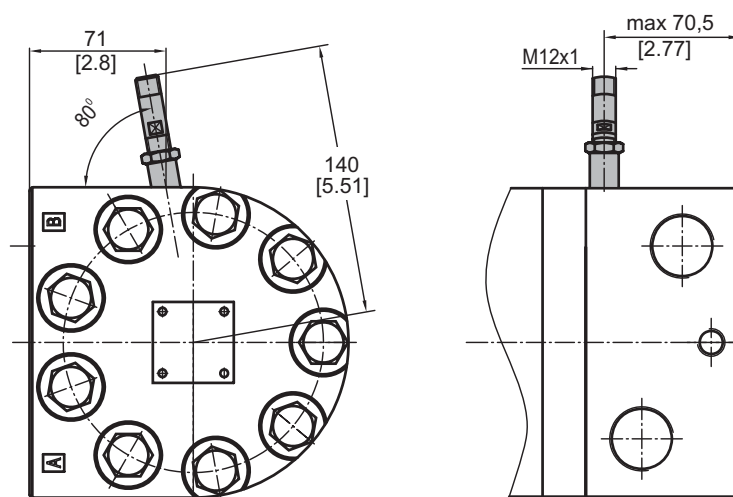

TECHNICAL DATA OF THE SPEED SENSOR

Technical data

Frequency range	0...15 000 Hz
Output	PNP, NPN
Power supply	10...36 VDC
Current input	20 mA (@24 VDC)
Ambient Temperature	-40...+125°C [-40...+257°F]
Protection	IP 67
Plug connector	M12-Series
Mounting principle	ISO 6149

Output signal

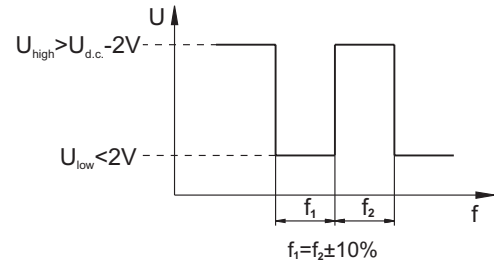

Load max.: $I_{high} = I_{low} < 50\text{mA}$

Motor type	MSWM	MTM TMF	MVM VMF
Pulses per revolution	54	84	102

Wiring diagrams

PNP

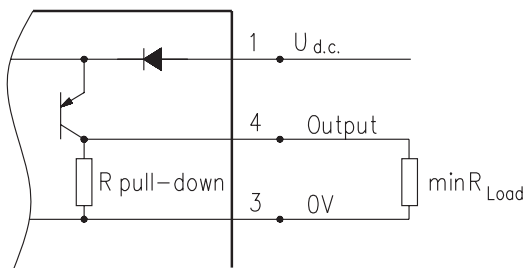

NPN

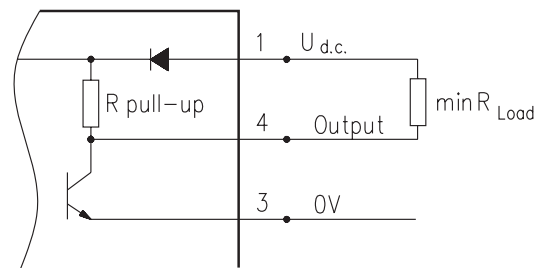

$$R_{Load} [\text{k}\Omega] = U_{d.c.} [\text{V}] / I_{max} [\text{mA}]$$

Stick type

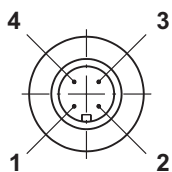

Terminal No.	Connection	Cable Output
1	$U_{d.c.}$	Brown
2	No connection	White
3	0V	Blue
4	Output signal	Black

Order Code for Speed Sensor

Sensor Code	Output type	Electric connection
RSN	NPN	Connector BINDER 713 series
RSP	PNP	Connector BINDER 713 series
RSNL5	NPN	Cable output 3x0,25; 5 m [196 in] long
RSPL5	PNP	Cable output 3x0,25; 5 m [196 in] long

NOTE: *- The speed sensor is not fitted at the factory, but is supplied in a plastic bag with the motor. For installation see enclosed instructions.

APPLICATION CALCULATION

VEHICLE DRIVE CALCULATIONS

1. Motor speed: n, RPM

$$n = \frac{2,65 \times v_{km} \times i}{R_m} \quad n = \frac{168 \times v_{mi} \times i}{R_m}$$

v_{km} - vehicle speed, km/h;

v_{mi} - vehicle speed, mil/h;

R_m - wheel rolling radius, m;

R_m - wheel rolling radius, in;

i - gear ratio between motor and wheels.

If no gearbox, use $i=1$.

2. Rolling resistance: RR, daN [lbs]

The resistance force resulted in wheels contact with different surfaces:

$$RR = G \times \rho$$

G - total weight loaded on vehicle, daN [lbs];

ρ - rolling resistance coefficient (Table 1).

Table 1

Rolling resistance coefficient In case of rubber tire rolling on different surfaces	
Surface	ρ
Concrete- faultless	0.010
Concrete- good	0.015
Concrete- bad	0.020
Asphalt- faultless	0.012
Asphalt- good	0.017
Asphalt- bad	0.022
Macadam- faultless	0.015
Macadam- good	0.022
Macadam- bad	0.037
Snow- 5 cm	0.025
Snow- 10 cm	0.037
Polluted covering- smooth	0.025
Polluted covering- sandy	0.040
Mud	0.037÷0.150
Sand- Gravel	0.060÷0.150
Sand- loose	0.160÷0.300

3. Grade resistance: GR, daN [lbs]

$$GR = G \times (\sin \alpha + \rho \times \cos \alpha)$$

α - gradient negotiation angle (Table 2)

Table 2

Grade %	α Degrees	Grade %	α Degrees
1%	0° 35'	12%	6° 5'
2%	1° 9'	15%	8° 31'
5%	2° 51'	20%	11° 19'
6%	3° 26'	25%	14° 3'
8%	4° 35'	32%	18°
10%	5° 43'	60%	31°

4. Accelerate force: FA, daN [lbs]

Force FA necessary for acceleration from 0 to maximum speed v and time t can be calculated with a formula:

$$FA = \frac{v_{km} \times G}{3,6 \times t}, [\text{daN}] \quad FA = \frac{v_{mi} \times G}{22 \times t}, [\text{lbs}];$$

FA - accelerate force, daN [lbs];

t - time, [s].

5. Tractive effort: DP, daN [lbs]

Tractive effort DP is the additional force of trailer. This value will be established as follows:

-acc.to constructor's assessment;

-as calculating forces in items 2, 3 and 4 of trailer; the calculated sum corresponds to the tractive effort requested.

6. Total tractive effort: TE, daN [lbs]

Total tractive effort TE is total effort necessary for vehicle motion; that the sum of forces calculated in items from 2 to 5 and increased with 10 % because of air resistance.

$$TE = 1,1 \times (RR + GR + FA + DP)$$

RR - force acquired to overcome the rolling resistance;

GR - force acquired to slope upwards;

FA - force acquired to accelerate (acceleration force);

DP - additional tractive effort (trailer).

7. Motor Torque moment: M, daNm [lb-in]

Necessary torque moment for every hydraulic motor:

$$M = \frac{TE \times R_m [R_m]}{N \times i \times \eta_m}$$

N - motor numbers;

η_m - mechanical gear efficiency (if it is available).

8. Cohesion between tire and road covering: M_w , daNm [lb-in]

$$M_w = \frac{G_w \times f \times R_m [R_m]}{i \times \eta_m}$$

To avoid wheel slipping, it should be observed the following condition $M_w > M$

f - frictional factor;

G_w - total weight over the wheels, daN [lbs].

Table 3

Surface	Frictional factor f
Steel on steel	0.15 ÷ 0.20
Rubber tire on polluted surface	0.5 ÷ 0.7
Rubber tire on asphalt	0.8 ÷ 1.0
Rubber tire on concrete	0.8 ÷ 1.0
Rubber tire on grass	0.4

9.Radial motor loading: P_{rad} , [daN]

When motor is used for vehicle motion with wheels mounted directly on motor shaft, the total radial loading of motor shaft P_{rad} is a sum of motion force and weight force acting on one wheel.

G_w - Weight held by wheel;

P_{rad} - Total radial loading of motor shaft;

M/R - Motion force.

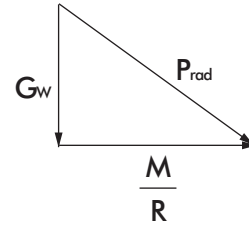

$$P_{rad} = \sqrt{G_w^2 + \left(\frac{M}{R}\right)^2}$$

In accordance with calculated loadings the suitable motor from the catalogue is selected.

DRAINAGE SPACE AND DRAINAGE PRESSURE

Advantages in oil drainage from drain space: Cleaning; Cooling and Seal lifetime prolonging.

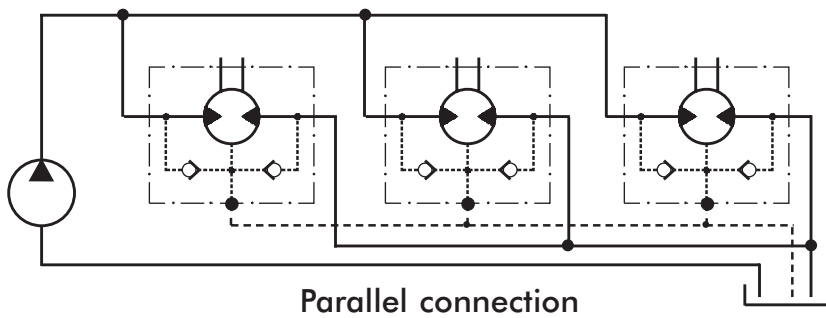
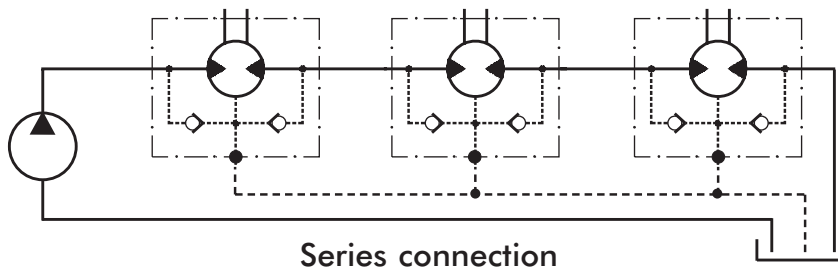

WARRANTY

M+S Hydraulic warrants, what its products, supplied directly to original equipment manufacturer, authorized distributor or other customer, will be free of defects in material or workmanship at the time of shipment from M+S Hydraulic and will conform to the products technical documentation (drawings and specifications) under sale agreement with Buyer.

This warranty will apply only to defects appearing within applicable Warranty period, mentioned below. If Buyer notify M+S Hydraulic within the Warranty period about any such defects, M+S , at its sole option will replace or repair the defective products or their parts found by M+S Hydraulic to be defective in material or workmanship.

THE FOREGOING LIMITED WARRANTY IS AVAILABLE ONLY IF "M+S HYDRAULIC" IS PROMPTLY NOTIFIED IN WRITING OF THE ALLEGED DEFECT AND DOES NOT COVER FAILURE TO FUNCTION CAUSED BY DAMAGE TO THE PRODUCT, IMPROPER INSTALLATION, UNREASONABLE USE OR ABUSE OF THE PRODUCT, FAILURE TO PROVIDE OR USE OF IMPROPER MAINTENANCE OR USUAL, DEGRADATION OF THE PRODUCT DUE TO PHYSICAL ENVIRONMENTS OF AN USUAL NATURE. THE FOREGOING REMEDIES ARE THE SOLE AND EXCLUSIVE REMEDIES AVAILABLE TO CUSTOMER. To facilitate the inspection, M+S Hydraulic may require return of the product/part, which Buyer claims to be defective.

M+S Hydraulic shall not be liable for labor costs or any other expenses incurred during the disassembling or reinstalling of the product/part.

In case the claimed products are returned to M+S Hydraulic in bad condition: dirty, disassembled, with damaged or missing parts during transportation, the warranty will be considered as not applicable and the products will not be liable to repair.

Warranty periods

New products: The Warranty period is limited to 24 consecutive months (2 years) from the date of production of the product.

Repaired products: If the product is repaired in M+S Hydraulic during its warranty period, the warranty period of the repaired item shall continue for the balance of original Warranty period or for a period equal to 50% of the original new product Warranty period, whichever is later.

Spare parts: The Warranty period for Spare parts shall be 12 consecutive months (1 year) from the dispatch date of such parts from M+S Hydraulic.

LIMITATION OF LIABILITY M+S Hydraulic's liability for any claim of any kind , for any loss or damage arising out of, connected with or resulting from an order, or from the performance or branch thereof, or from the design, manufacture, sale delivery, operation or use of any of its products shall be limited to , at M+S 's sole option, replacement, repair of any defective product or the issuance of a credit to Customer against any future purchases. Cash refunds will not be made under any circumstances and Customer will not be entitled to recover any damages of any kind against M+S Hydraulic, including but not limited to incidental or consequential damages, whether direct or indirect, known or unknown, foreseen or unforeseen.